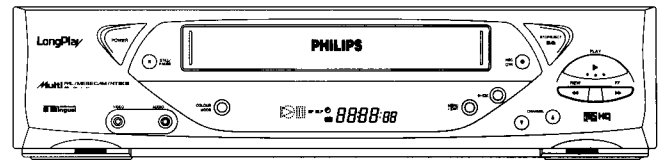


Service Service Service



VR488/55

Service Manual

Contents

Chapter	
	Disassembly
2	Mechanism adjustments
3	Electrical adjustments
4	Charts and diagrams
5	Parts lists

Specification:

Video recording system:	Rotary 4-head helical scan system
Antenna input Signal:	PAL B/G, D/K, I, SECAM, K1
Antenna:	VHF/UHF 75Ω external antenna terminal
UHF Output Signal:	UHF ch 36 (adjustable between 28 to 60) 75Ω unbalanced
Power requirement:	AC 110V – 240V, ~ 50/60Hz
Power consumption:	18W
Operating temperature:	+41°F (5°C) to 104°F (40°C)
Relative humidity:	10% to 80%
Weight:	3.3kg
Dimensions:	400 x 94 x 272mm VR488/55 400 x 94 x 276mm VR588/55

Safety regulations require that the set be restored to its original condition and that parts which are identical with those specified be used.



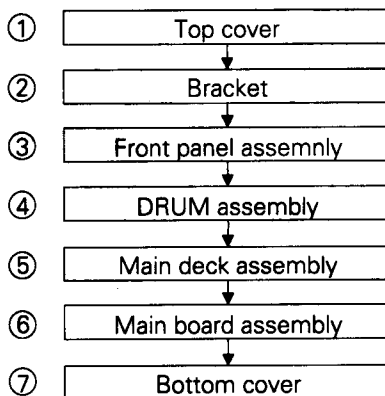
TABLE OF CONTENTS

Section	Title	Page
1. DISASSEMBLY		
1.1	DISASSEMBLY FLOW CHART	1-1
1.2	HOW TO READ THE DISASSEMBLY AND ASSEMBLY	1-1
1.3	DISASSEMBLY/ASSEMBLY METHOD	1-1
1.4	SERVICE POSITION	1-4
1.5	MECHANISM SERVICE MODE	1-5
1.6	EMERGENCY DISPLAY FUNCTION	1-6
1.7	SYSCON CIRCUIT	1-7
2. MECHANISM ADJUSTMENT		
2.1	BEFORE STARTING REPAIR AND ADJUSTMENT	2-1
2.2	REPLACEMENT OF MAJOR PARTS	2-7
2.3	MAJOR PARTS INSTALLATION (PHASE MATCHING BETWEEN MECHANICAL PARTS)	2-19
2.4	COMPATIBILITY ADJUSTMENT	2-21
3. ELECTRICAL ADJUSTMENT		
3.1	PRECAUTION	3-1
3.2	SERVO CIRCUIT	3-2
3.3	VIDEO CIRCUIT	3-3
3.4	SYSCON CIRCUIT	3-3
3.5	ON SCREEN CIRCUIT ..	3-4
4. CHARTS AND DIAGRAMS		
	NOTES OF SCHEMATIC DIAGRAM	4-1
	CIRCUIT BOARD NOTES	4-2
4.1	BOARD INTERCONNECTIONS	4-3
4.2	VIDEO/N.AUDIO SCHEMATIC DIAGRAM	4-5
4.3	ON SCREEN SCHEMATIC DIAGRAM	4-7
4.4	SYSCON SCHEMATIC DIAGRAM	4-9
4.5	SWITCHING REGULATOR SCHEMATIC DIAGRAM	4-11
4.6	TUNER SCHEMATIC DIAGRAM	4-13
4.7	SW/DISPLAY SCHEMATIC DIAGRAM	4-15
4.8	TERMINAL SCHEMATIC DIAGRAM	4-17
4.9	CAP MOTOR SUB SCHEMATIC AND CIRCUIT BOARD	4-20
4.10	MAIN AND A/C HEAD CIRCUIT BOARDS	4-21
4.11	FDP GRID ASSIGNMENT AND ANODE CONNECTION	4-24
4.12	REMOTE CONTROL SCHEMATIC DIAGRAM	4-25
4.13	VOLTAGE CHARTS	4-26
4.14	SYSTEM CONTROL BLOCK DIAGRAM	4-29
4.15	VIDEO BLOCK DIAGRAM	4-31
4.16	AUDIO BLOCK DIAGRAM	4-33
5. PARTS LIST		
5.1	ACCESSORIES AND ASSEMBLY <M1>	5-1
5.2	CABINET AND CHASSIS ASSEMBLY <M2>	5-3
5.3	MECHANISM ASSEMBLY <M4>	5-5
5.4	ELECTRICAL PARTS LIST	5-5

SECTION 1 DISASSEMBLY

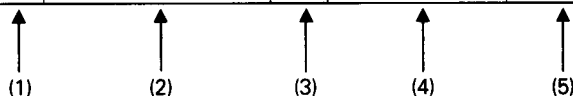
1.1 DISASSEMBLY FLOW CHART

This flowchart lists the disassembling steps for the cabinet parts and P.C. boards in order to gain access to item(s) to be serviced. When reassembling, perform the step(s) in reverse order. Bend, route and dress the flat cables as they were originally laid.



1.2 HOW TO READ THE DISASSEMBLY AND ASSEMBLY

STEP /LOC NO.	PART NAME	FIG. NO.	POINT	NOTE
①	TOP COVER	D1	4(S1), 1(S2)	
②	BRACKET	D2	2(S3)	
③	FRONT PANEL ASSEMBLY	D3	7(L1)	<NOTE 1> <NOTE 2>
④	DRUM ASSEMBLY	D4	3(S4),WR1,*CN1 1(L2),CLEANER ASSY	<NOTE 3>
⑤	MAIN DECK ASSEMBLY	D5	2(S5),2(S6),WR2, 2(L3), *CN2001	<NOTE 4>
⑥	MAIN BOARD ASSEMBLY	D6	3(S7),1(S8),1(S9) 6(L4)	
⑦	BOTTOM COVER	D7	2(L5), 10(L6)	<NOTE 5>



- (1) Order of steps in Procedure
When reassembling, perform the step(s) in the reverse order. These numbers are also used as the identification (location) NO. of parts Figures.
- (2) Part name to be removed or installed.
- (3) Fig.No. showing procedure or part location
- (4) Identification of part to be removed, unhooked, unlocked, released, unplugged, unclamped or unsoldered. P = Spring, W = Washer, S = Screw, L = Locking tab, * = Unhook, unlock, release, unplug or unsolder.
- (5) Adjustment information for installation

1.3 DISASSEMBLY/ASSEMBLY METHOD

STEP /LOC NO.	PART NAME	FIG. NO.	POINT	NOTE
①	TOP COVER	D1	4(S1), 1(S2)	
②	BRACKET	D2	2(S3)	
③	FRONT PANEL ASSEMBLY	D3	7(L1)	<NOTE 1> <NOTE 2>
④	DRUM ASSEMBLY	D4	3(S4),WR1,*CN1 1(L2),CLEANER ASSY	<NOTE 3>
⑤	MAIN DECK ASSEMBLY	D5	2(S5),2(S6),WR2, 2(L3), *CN2001	<NOTE 4>
⑥	MAIN BOARD ASSEMBLY	D6	3(S7),1(S8),1(S9) 6(L4)	
⑦	BOTTOM COVER	D7	2(L5), 10(L6)	<NOTE 5>

<NOTE1>

When reattaching the Front panel assembly, make sure that the door opener (a) of the Cassette holder assembly is lowered in position prior to the reinstallation.

<NOTE2>

When reattaching the Front panel assembly, pay careful attention to the switch lever not to make it touch the REC switch knob (b) of the Main board assembly from the side. (If the REC switch knob of the Main board assembly is damaged, cassette loading is impossible.)

<NOTE3>

When plugging the connector in, check that the flat wire is inserted properly and fully.

<NOTE4>

- When removing the Main deck assembly only, unhook the two spacers connecting it with the Main board assembly with pliers from the back side of the Main board assembly first, and then remove the Main deck assembly.
- When reattaching the Main deck assembly to the Main board assembly, take care not to damage the sensors on the Main board (D3001: LED, Q3001: Start sensor, Q3002: End sensor).

<NOTE5>

When remove the bottom cove, push down the two L4(S) to slide front panel.

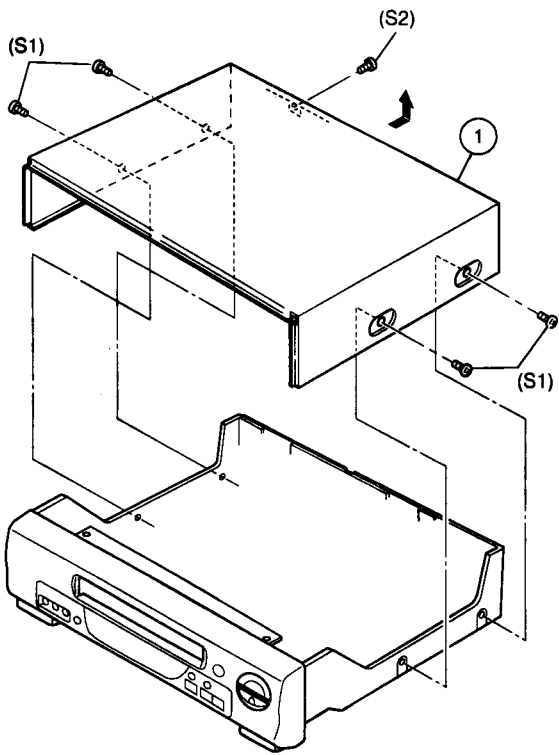


Fig. D1

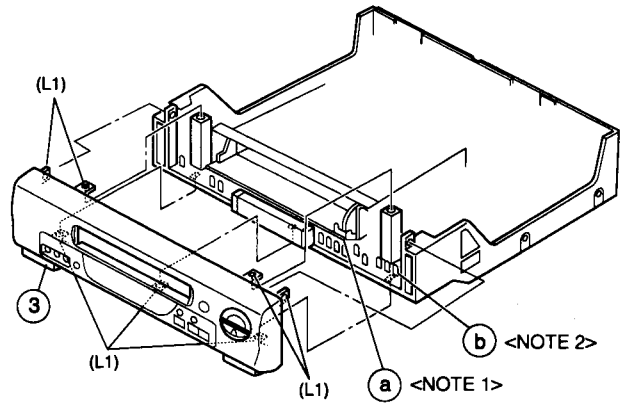


Fig. D3

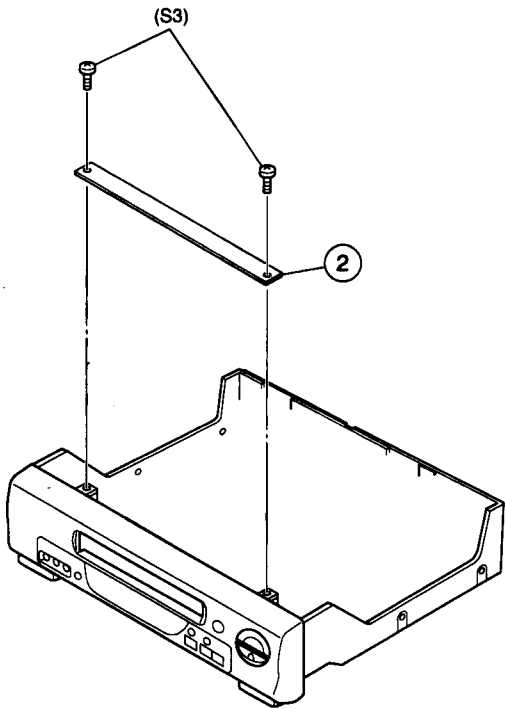


Fig. D2

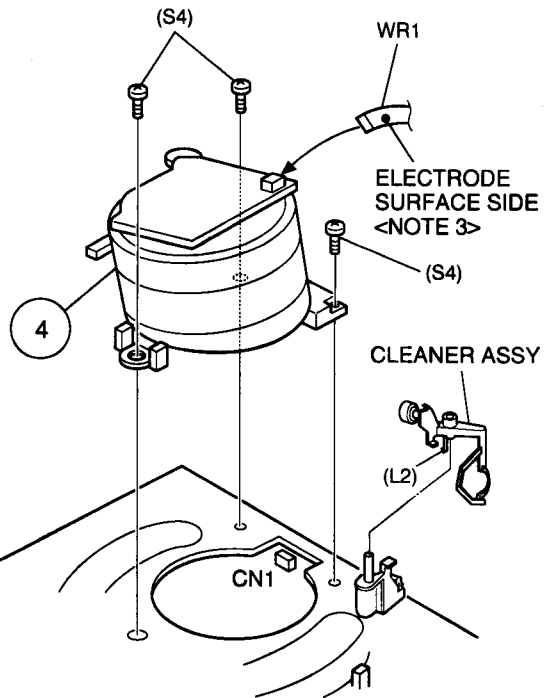


Fig. D4

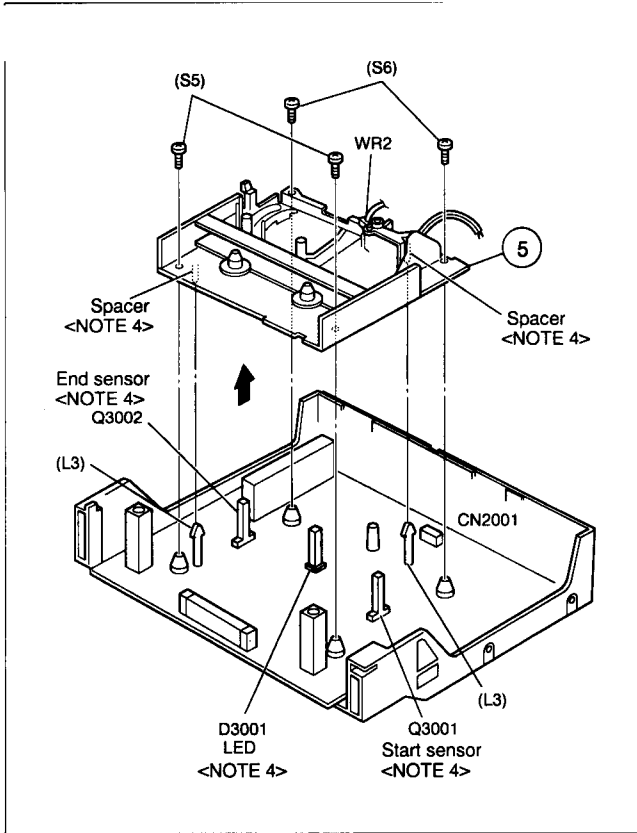


Fig. D5

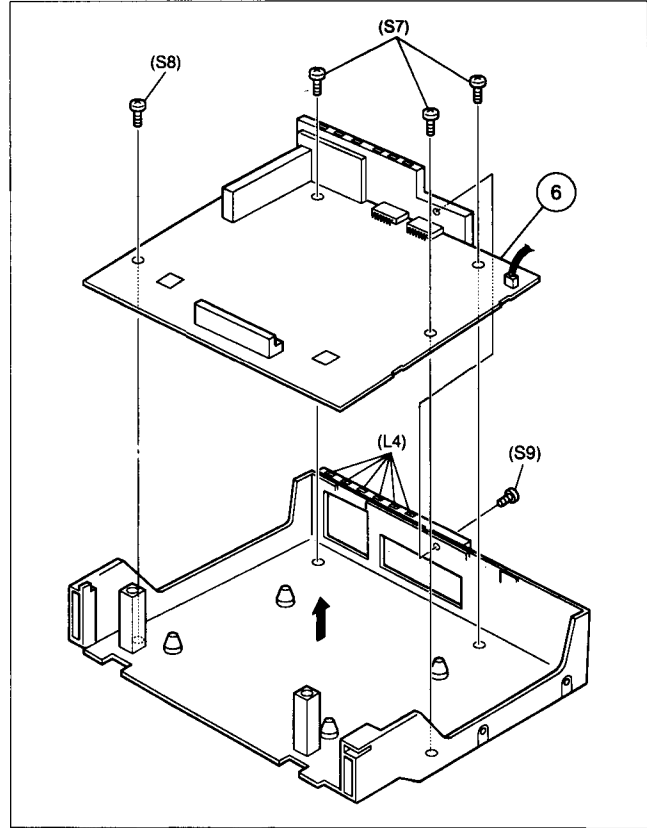


Fig. D6

Procedures for Lowering the Cassette holder assembly

As the mechanism of this unit is integrated with the Housing assembly, the holder must be lowered and the two bolts unscrewed when removing the Main deck assembly.

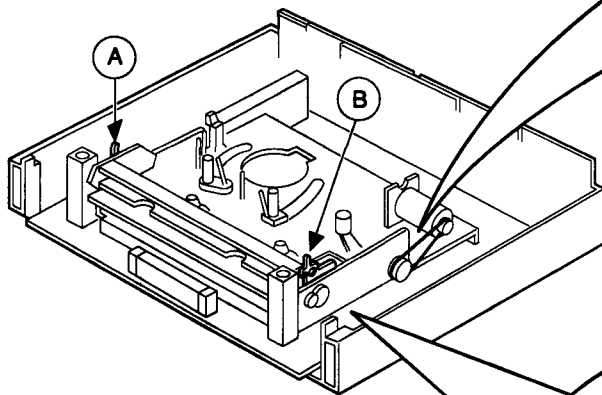


Fig. 1

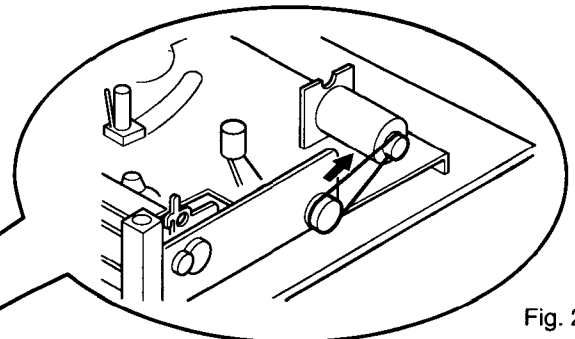


Fig. 2

Turn the loading motor pulley in the direction as indicated by Fig.2. As both (A) and (B) levers are lodged twice, push the levers in the direction as indicated by Fig.3 to release them. When pushing the levers, do it in the order of (A), (B), (B), (A). When the holder has been lowered, turn the pulley until the cassette holder is securely in place without allowing any up/down movement.

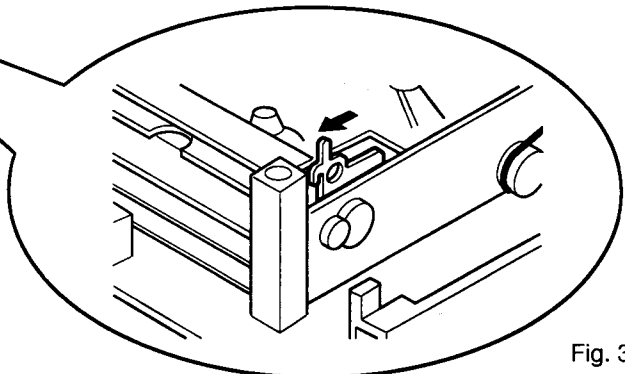


Fig. 3

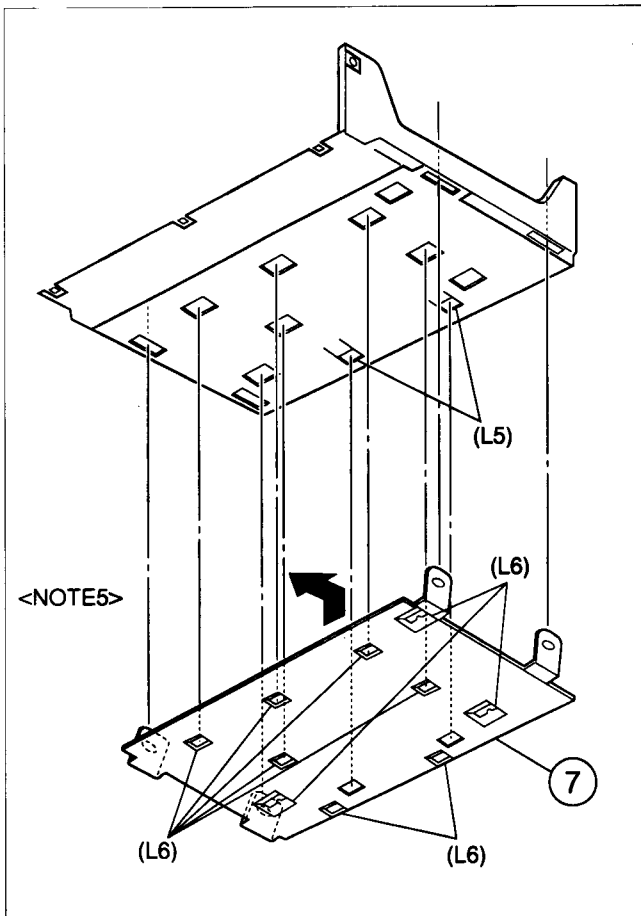


Fig. D7

1.4 SERVICE POSITION

In order to facilitate diagnosis and the repair of the Main deck assembly, this unit is constructed so as to allow the Main deck and the Main board assemblies to be removed together from the Chassis assembly.

1.4.1 How to take out the Mechanism and Main board

- (1) Remove the Top cover, Bracket and Front panel assembly. (See 1.3 DISASSEMBLY/ASSEMBLY METHOD. Take care not to pull the drum wire (Fig.D4) from CN1).
- (2) Lower the cassette holder, and make the preparations required in order to remove the bolts from the Main deck assembly (Refer to the "Procedures for Lowering the Cassette holder assembly" on pages 1-3 of 1.3 DISASSEMBLY/ASSEMBLY METHOD).
- (3) Take out 2 screws (A) and 2 screws (B) as shown in Fig. 1-4-1.

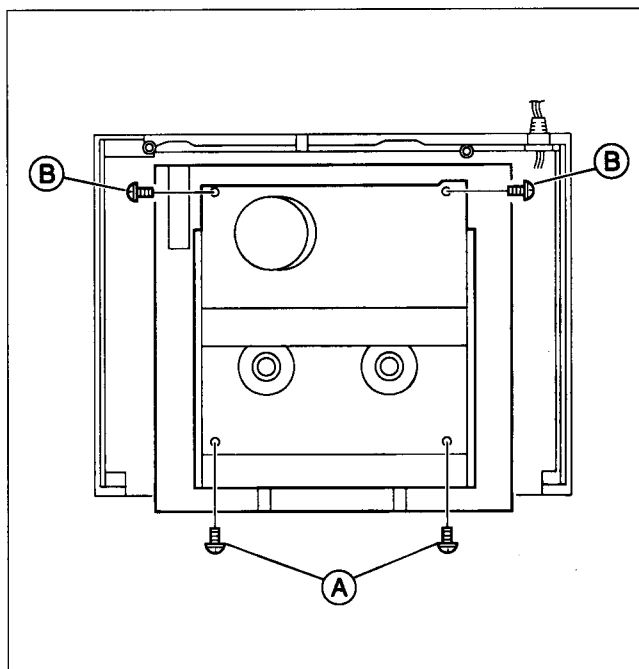


Fig. 1-4-1

- (4) Take out 3 screws (D), 1 screw (C), and 1 screw (E).
- (5) Remove the Main board and Main deck assemblies together while holding the edge of the Main board. At this stage be careful of the power cord and prongs of the jacks on the back side (See Fig. 1-4-2).

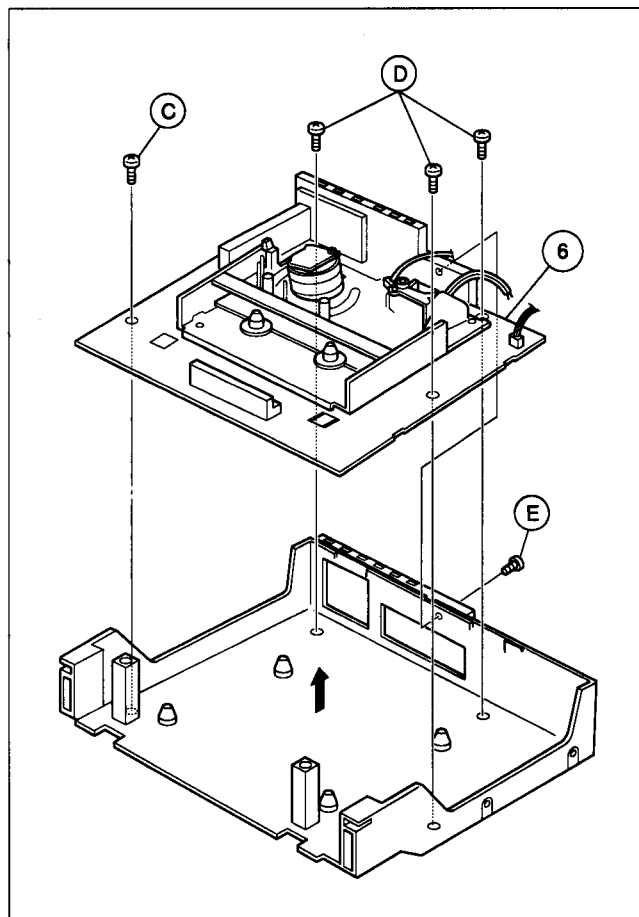


Fig. 1-4-2

- (6) Connect the power cord to the wall socket, and lift the cassette holder.
(Before turning on the power make sure that there is nothing which may produce a short circuit, such as faulty soldering.)
- (7) When performing a diagnosis or repair of the Main board assembly with a cassette tape in place, turn on the power, insert a cassette tape, and turn over the Main board and Main deck assemblies together.

Notes:

- When carrying out diagnosis and repair of the Main board assembly in the service position, be sure to ground both the Main board assembly and the Mechanism assemblies.
If they are improperly grounded, there may be noise on the playback picture or the FDP counter display may move even when the mechanism is kept in an inoperative status.
- When the unit is operated upside-down, it must be level or the takeup reel will not turn. Level the unit by placing a non-conducting material under the front side or by holding down the back side of the main board assembly.
- When performing playback of the tape or carrying out a diagnosis of recording in the service position, set the unit to the Play or Record mode before turning the unit around.
- Do not change the mode when carrying out diagnosis. Be sure to set the unit front side up when switching the mode.

1.5 MECHANISM SERVICE MODE

This model has a unique function to enter the mechanism into every operation mode without loading of any cassette tape. This function is called the "MECHANISM SERVICE MODE".

1.5.1 How to set the "MECHANISM SERVICE MODE"

- (1) Disconnect VCR from AC.
- (2) Lower the cassette holder (Refer to the "Procedures for Lowering the Cassette holder assembly" on pages 1-3 of 1.3 DISASSEMBLY/ASSEMBLY METHOD).
- (3) Connect TP GND AND TP7001 (TEST) on the Main board assembly with a jump wire.
- (4) Connect VCR to AC.
- (5) Press the POWER button.
- (6) Select the desired operation modes with the operation buttons or remote controller.

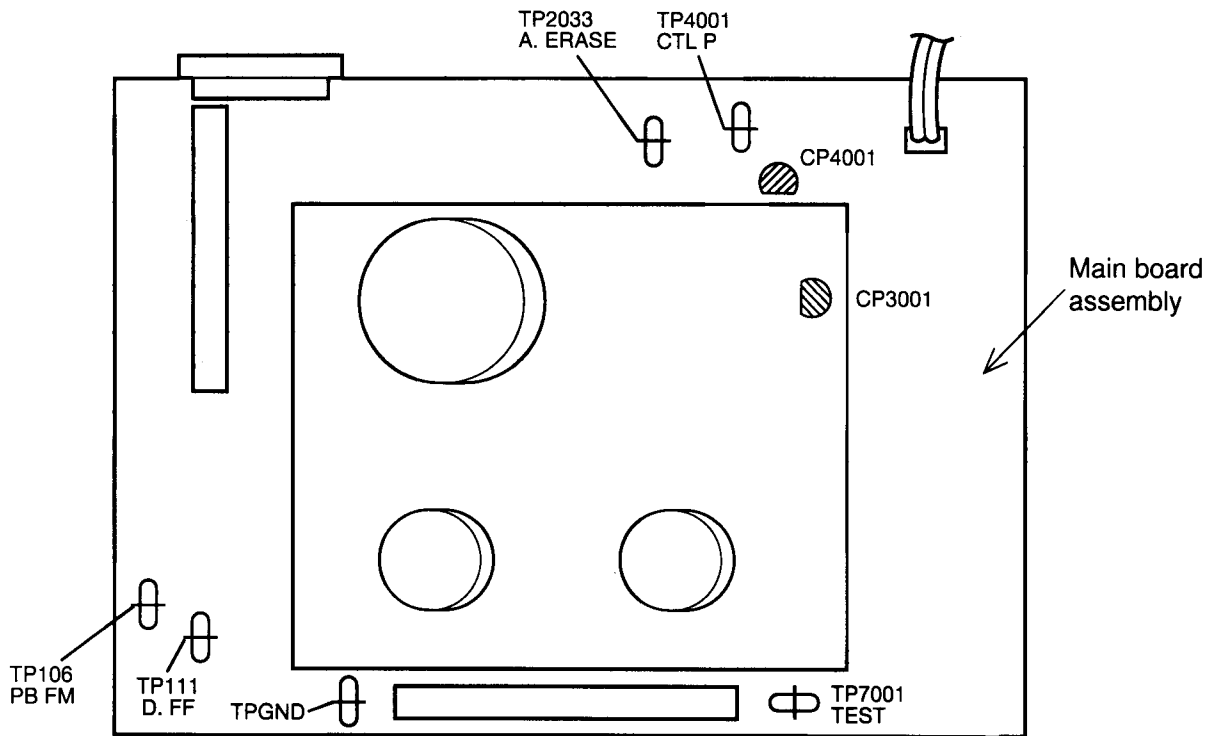


Fig. 1-5-1

1.6 EMERGENCY DISPLAY FUNCTION

This product has the function to store the last two previous emergency faults which can be displayed in the FDP when servicing.

1.6.1 How to display record of an emergency faults

Note: Put the unit into A mode by using the VCR remote control. (When it is in B mode, the preset remote control codes are not accepted.)

- (1) Press "N" button of the presetting unit More than 2 seconds and the two previous emergency faults are shown in the LED or FDP.
- (2) Press "N" button of the presetting unit again to return to the normal mode.

[Example] E : 01 : 03

↑ Emergency fault before last

↑ Emergency fault of the last time

[Example] E : --- : --- ← No record of emergency

1.6.3 How to clear emergency record

Press the COUNTER RESET button on the remote controller in the emergency record display mode, and the record of the emergency fault(s) is cleared.

1.6.2 Detail of emergency faults

EMG DATA	Symptom	Detect mode	Resulting mode
E --	No EMERGENCY		
E 01	Loading motor rotates for more than 4 Sec without shift to next mode.	Loading	POWER OFF
E 02	Loading motor rotates for more than 4 Sec without shift to next mode.	Unloading	POWER OFF
E 03	TU or SUP REEL FG input is absent. (for more than 4 Sec)	REC/PLAY/FF/REW SEARCH FF/SEARCH REW	STOP → POWER OFF
E 04	DRUM FF input is absent. (for more than 3 Sec)	REC/PLAY/FF/REW SEARCH FF/SEARCH REW	STOP → POWER OFF
E 05	(NOT USED)	—	—
E 06	CAPSTAN FG input is absent. (for more than 4 Sec)	REC/PLAY/FF/REW SEARCH FF/SEARCH REW	STOP → POWER OFF
E 07	No SWD5V/12V	POWER ON	POWER OFF

Table 1-6-1 EMERGENCY FAULTS-1

1.7 SYSCON CIRCUIT

1.7.1 Syscon CPU pin function (IC3001) 1/2

PIN NO.	LABEL	IN/OUT	NOTE
1	S CURVE/AFT	IN	DC FLUCTUATES BY THE TU RECEIVES SENSITIVITY (USED FOR TUNER SEARCH).
2	START SENSOR	IN	LEADER TAPE DETECT (DETECT ON: L)
3	CTL GAIN	OUT	CONTROL PULSE GAIN CONTROL
4	RF AGC	IN	NC
5	END SENSOR	IN	TRAILER TAPE DETECT (DETECT ON: L)
6	BUSY	IN	NC
7	FDPCS	OUT	FDP IC CHIP SELECT
8	SECAM[H]	OUT	NC
9	VIDEO ENV.	IN	VIDEO PB FM INPUT
10	PROTECT	IN	SWD 5V/12V DETECT
11	NC	-	NC
12	V. PULSE	OUT	V. PULSE ADDITION TIMING CONTROL
13	N. REC ST (H)	OUT	REC START: H
14	RC IN	IN	REMOTE CONTROL DATA INPUT
15	N. REC [H]	OUT	"H" IS OUTPUT DURING REC AND REC PAUSE.
16	SYNC DET [H]	IN	OSD IC DETERMINES THE PRESENCE OR ABSENCE OF SYNC AND OUTPUTS "H" FOR SYNC. THIS RECEIVES THE "H" OUTPUT OF "H".
17	LOCK DET [L]	IN	THE TU UNIT OUTPUTS "L" WHEN RECEIVING A CERTAIN CH. THIS RECEIVES THE "L" OUTPUT AND VERIFIES THE TU RECEPTION.
18	D. FF	OUT	VIDEO PB FM (CH-1, CH-2) SWITCHING PULSE
19	A. FF	-	NC
20	NC	-	NC
21	NC	-	NC
22	NC	-	NC
23	A. MUTE [H]	OUT	OUTPUTS "H" DURING AUDIO MUTE, SUCH AS FOR SPECIAL PLAYBACK, CH UP/DOWN, AND POWER ON/OFF.
24	B/W[H]	OUT	NC
25	3.58NT [H]	OUT	NC
26	LMC1	OUT	LOADING MOTOR DRIVE (1)
27	LMC2	OUT	LOADING MOTOR DRIVE (2)
28	LMC3	OUT	LOADING MOTOR DRIVE (3)
29	CASS SW	-	NC
30	REC SAFETY	IN	REC SAFETY SWITCH DETECT (SW ON: L)
31	LSC	IN	MECHANISM MODE DETECT (C)
32	LSB	IN	MECHANISM MODE DETECT (B)
33	LSA	IN	MECHANISM MODE DETECT (A)
34	NUB	-	NC
35	NUA	-	NC
36	CLK_SEL	IN	SELECTION OF EITHER MAIN X'TAL OR SUB X'TAL AS X'TAL FOR CLOCK.
37	VCC	IN	SYSTEM POWER
38	X IN	IN	SYSTEM CLOCK
39	X OUT	OUT	SYSTEM CLOCK
40	VSS	IN	GND
41	XC IN	IN	TIMER CLOCK
42	XC OUT	OUT	TIMER CLOCK
43	RESET	IN	RESET AT CONNECT VCR TO AC
44	P CTL (H)	OUT	POWER ON/OFF CONTROL (POWER ON: H)
45	TUNER CLK	OUT	SERIAL DATA SHIFT CLOCK OUTPUT
46	TU CE	OUT	TUNER UNIT CHIP ENABLE
47	TUNER DATA	OUT	TUNING CONTROL SERIAL DATA OUTPUT
48	TU_MUTE[H]	OUT	NC
49	SP [L]	-	NC
50	BEST CTL	-	NC

Table 1-7-1 SYSCON CPU pin function(1/2)

1.7.2 Syscon CPU pin function (IC3001) 2/2

PIN NO.	LABEL	IN/OUT	NOTE
51	SECAM TU ON [L] M/DK [H]	OUT	OUTPUTS "L" WHEN RECEIVING A SECAM BROADCAST.
52	P MUTE (L)	OUT	PICTURE MUTE CONTROL (MUTE ON: L)
53	SUB 0	-	NC
54	SUB 1	-	NC
55	WAKE UP	OUT	NC
56	IP_ON[H]	-	NC
57	SCR [H]	IN	NC
58	POWER SAVE	OUT	OUTPUTS "L" DURING POWER SAVE, AND "H" OTHERWISE.
59	SECAM VL[H]/M/BG [H]	OUT	OUTPUTS "H" WHEN RECEIVING A SECAM VL BROADCAST.
60	SUB CPU RESET	OUT	NC
61	SUB CPU CS	OUT	NC
62	EE [L]	OUT	OUTPUTS "L" WHEN VTR OUTPUTS EE PICTURES, AND "H" DURING PLAYBACK.
63	SECAM DET [H]	IN	NC
64	OSD CS	OUT	ON SCREEN IC CHIP ENABLE
65	SUB OUT	OUT	NC
66	SUB IN	IN	NC
67	SUB CLK	OUT	NC
68	DATA O	OUT	SERIAL DATA OUTPUT (TO OSD IC AND FDP IC)
69	DATA I	IN	SERIAL DATA INPUT (FROM FDP IC)
70	S CLK	OUT	SERIAL DATA TRANSFER CLOCK OUTPUT (TO OSD IC AND FDP IC)
71	TEST/I2C CLK	OUT	SERIAL DATA TRANSFER CLOCK TO EEPROM IC, AV1CHIP IC, CH+ IC AND ATS+ IC etc.
72	I2C DATA	OUT	SERIAL DATA OUTPUT TO EEPROM IC, AV1CHIP IC, CH+ IC AND ATS+ IC etc.
73	PB SPE [L]	OUT	OUTPUTS "L" DURING SPECIAL PLAYBACK.
74	NC	-	NC
75	NC	-	NC
76	CAP REV (L)	OUT	CAPSTAN MOTOR CONTROL (FWD: H/REV: L)
77	CAP CTL V	OUT	CAPSTAN MOTOR CONTROL VOLTAGE
78	DRUM CTL V	OUT	DRUM MOTOR CONTROL VOLTAGE
79	SP FG	IN	SUPPLY REEL ROTATION DET/TAPE REMAIN
80	TU FG	IN	TAKE-UP REEL ROTATION DET/TAPE REMAIN
81	R. PAUSE_IN	IN	NC
82	POWER DET	IN	A PORT TO VERIFY THAT AL POWER IS UP. NORMALLY AT "L".
83	C	-	NC
84	C. SYNC	IN	COMPOSITE SYNC
85	C. FG IN	IN	CAPSTAN FG PULSE INPUT
86	D. PG IN	IN	DRUM PICKUP PULSE INPUT (SWITCHING PULSE)
87	D. FG IN	IN	DRUM FG PULSE INPUT
88	AMP VSS	-	GND(ANALOG AMP)
89	AMP V REF OUT	-	AMP CIRCUIT REFERENCE VOLTAGE OUTPUT
90	AMP V REF IN	-	AMP CIRCUIT REFERENCE VOLTAGE INPUT
91	CTL-	IN/OUT	CTL (-) SIGNAL
92	CTL+	IN/OUT	CTL (+) SIGNAL
93	CTL SW OUT	OUT	CTL SWITCH OUTPUT
94	CTL AMP IN	IN	CTL AMP INPUT
95	AMP C	IN	CAPACITOR CONNECT TERMIAL FOR CTL AMP CIRCUIT
96	CTL VSS	-	CTL AMP CIRCUIT REFERENCE V _{ss}
97	CTL AMP OUT	OUT	CTL AMP OUTPUT
98	AMP VCC	IN	CTL AMP POWER, ANALOG AMP POWER
99	AVCC	IN	SYSTEM POWER, AD/DA CONVERT STANDARD VOLTAGE
100	MESECAM DET [H]	IN	"H" IS INPUT DURING PLAYBACK OR WHEN THE EXTERNAL INPUT SIGNALS ARE MESECAM.

Table 1-7-2 SYSCON CPU pin function(2/2)

SECTION 2 MECHANISM ADJUSTMENT

2.1 BEFORE STARTING REPAIR AND ADJUSTMENT

2.1.1 Precautions

- (1) Unplug the power cable of the main unit before using your soldering iron.
- (2) Take care not to cause any damage to the conductor wires when plugging and unplugging the connectors.
- (3) Do not randomly handle the parts without identifying where the trouble is.
- (4) Exercise enough care not to hurt yourself, especially your finger nails, during the repair work.
- (5) When installing the front panel assembly, be sure to hook the lug on the back side of cassette door to the door opener of the cassette holder. If this operation is neglected it will not be possible to remove the cassette when ejecting because the housing door cannot be opened.

2.1.2 Checking for Proper Mechanical Operations

Enter the mechanism service mode when you want to operate the mechanism when no cassette is loaded. (See 1.5 MECHANISM SERVICE MODE)

2.1.3 Manually Removing the Cassette Tape

1. In case of electrical failures

If you cannot remove the cassette tape which is loaded because of any electrical failure, manually remove it by taking the following steps.

- (1) Unplug the power cable and remove the top cover, bracket and, front panel assembly.
(See 1.3 DISASSEMBLY/ASSEMBLY METHOD)
- (2) Unload the cassette by manually turning the unloading motor of the main deck assembly toward the front. In doing so, hold the tape by the hand to keep the slack away from any grease. (See Fig.2-1-1)
- (3) Bring the pole base assembly (on the supply or take-up side) to a pause when it reaches the position where it is hidden behind the cassette tape.
- (4) Move the top plate toward the drum while holding down the lug **(A)** of the bracket retaining the top plate. Likewise hold part **(B)** down and remove the top plate. The spring plate **(C)** is then brought under the cassette lid. Then remove the top plate by pressing the whole cassette tape down. (Note 1) (See Fig.2-1-2).
- (5) Remove the cassette tape by holding both the slackened tape and the cassette lid.
- (6) Take up the slack of the tape into the cassette. This completes removal of the cassette tape.

Note: *The spring plate of the top plate is sharp-edged. Take care not to hurt yourself.*

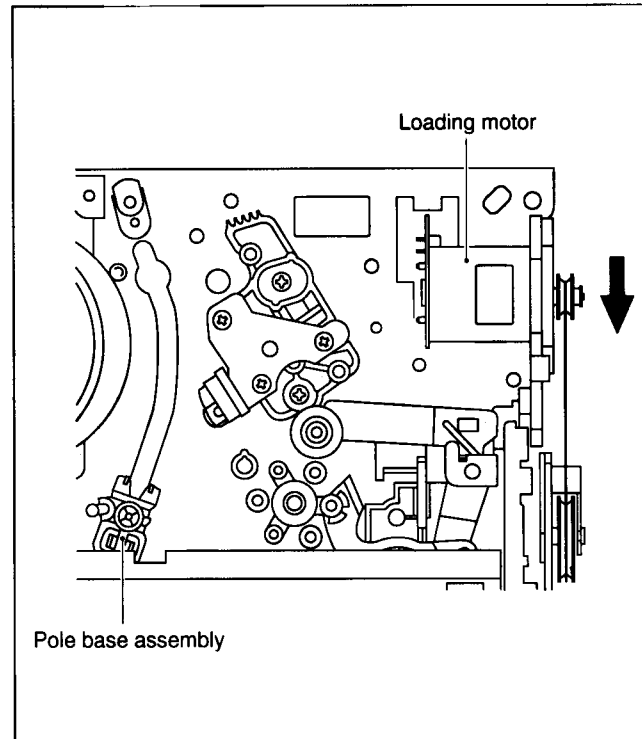


Fig. 2-1-1

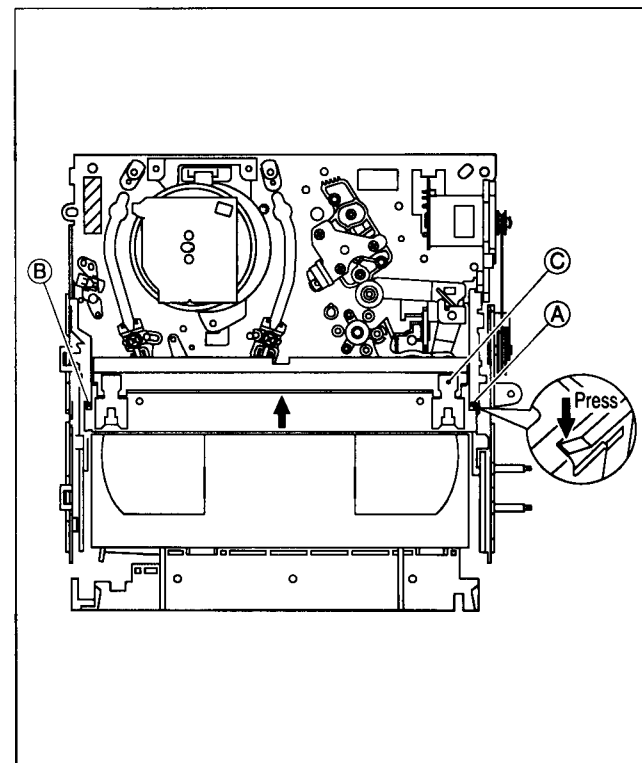


Fig. 2-1-2

2. In case of mechanical failure

If you cannot remove the cassette tape which is loaded because of any mechanical failure, manually remove it by taking the following steps.

- (1) Unplug the power cable and remove the top cover, bracket, front panel assembly, stay and Drum shield (See 1.3 DISASSEMBLY/ASSEMBLY METHOD).
- (2) While keeping the tension arm of the main deck assembly free from tension, pull the tape on the pole base assembly out of the guide roller (on the supply or take-up side) (See Fig.2-1-3).

(3) Remove the top plate as done in Step (4) of "1. In case of electrical failures" and remove the guide pole cap at the same time. (See Fig.2-1-4).

(4) While lifting the cassette tape lid, hold the cassette tape case and pinch roller by the fingers and move them toward the loading motor to relieve pressure on the tape. Then remove the tape while taking the cassette case out of the cassette holder. (See Fig.2-1-4).

(5) Replace the guide pole cap and take up the slack of the tape into the cassette.

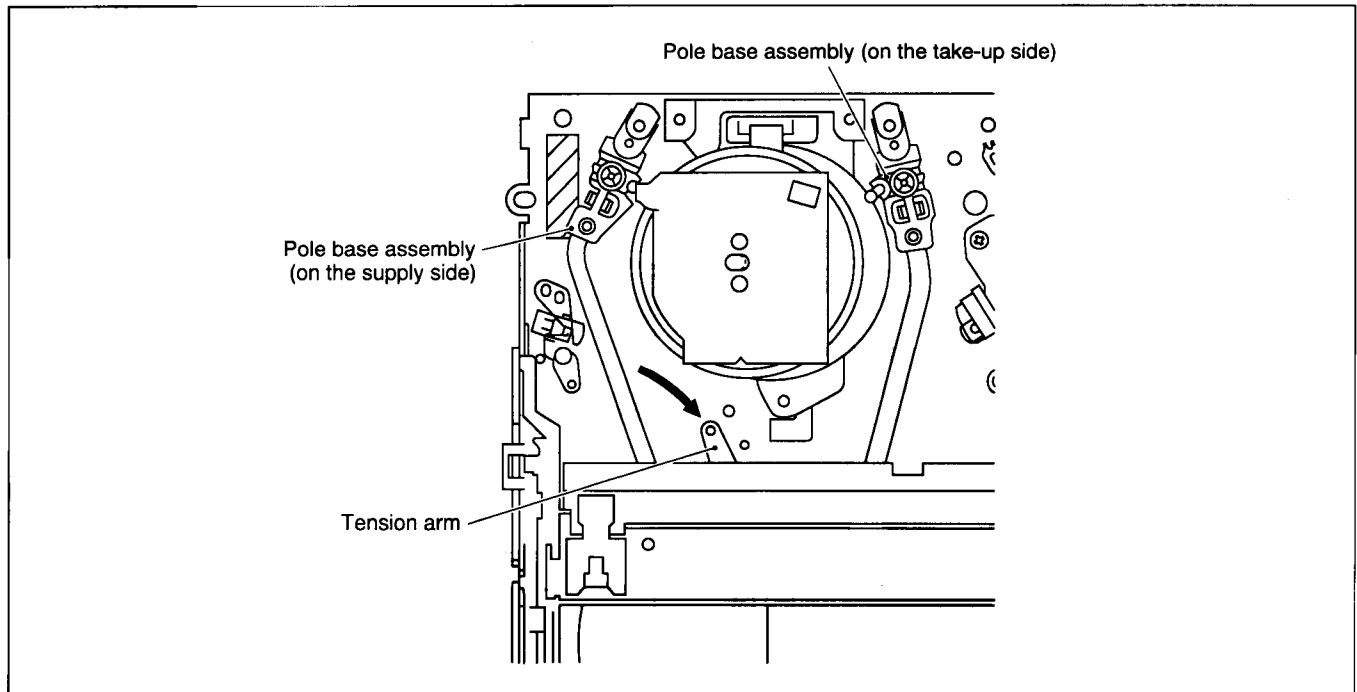


Fig. 2-1-3

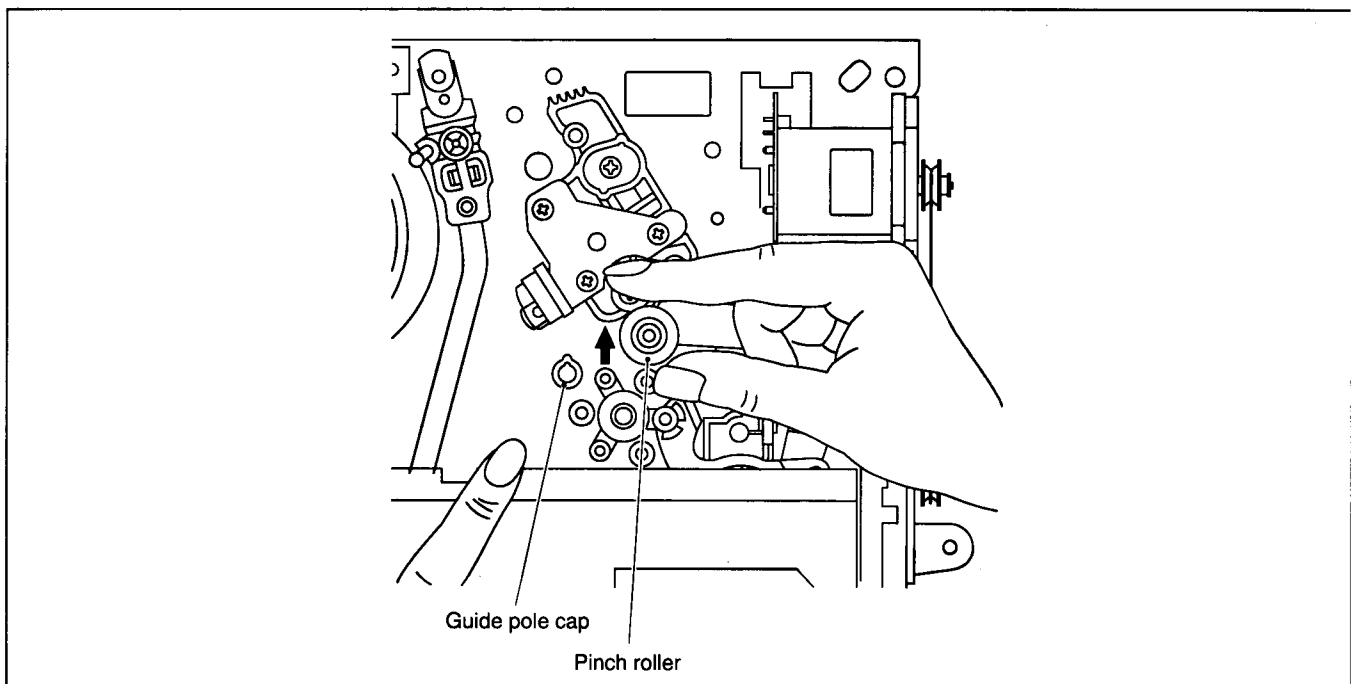


Fig. 2-1-4

2.1.4 Jigs and Tools Required for Adjustment

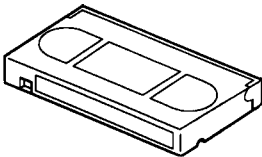
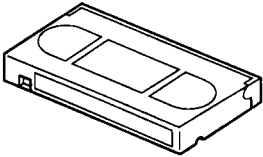
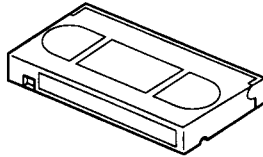

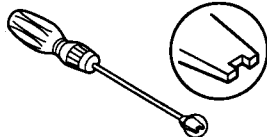
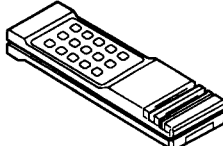
Alignment tape (SP) 4822 397 30262	Alignment tape (LP) 4822 397 30261	Back tension cassette gauge 4822 395 90615	A/C head position bit 4822 395 90916
			
Roller driver 4822 395 90904	Presetting unit 4822 395 90915		
			

Table 2-1-1 Jigs and tools required for adjustment

2.1.5 Maintenance and Inspection

1. Location of major mechanical parts

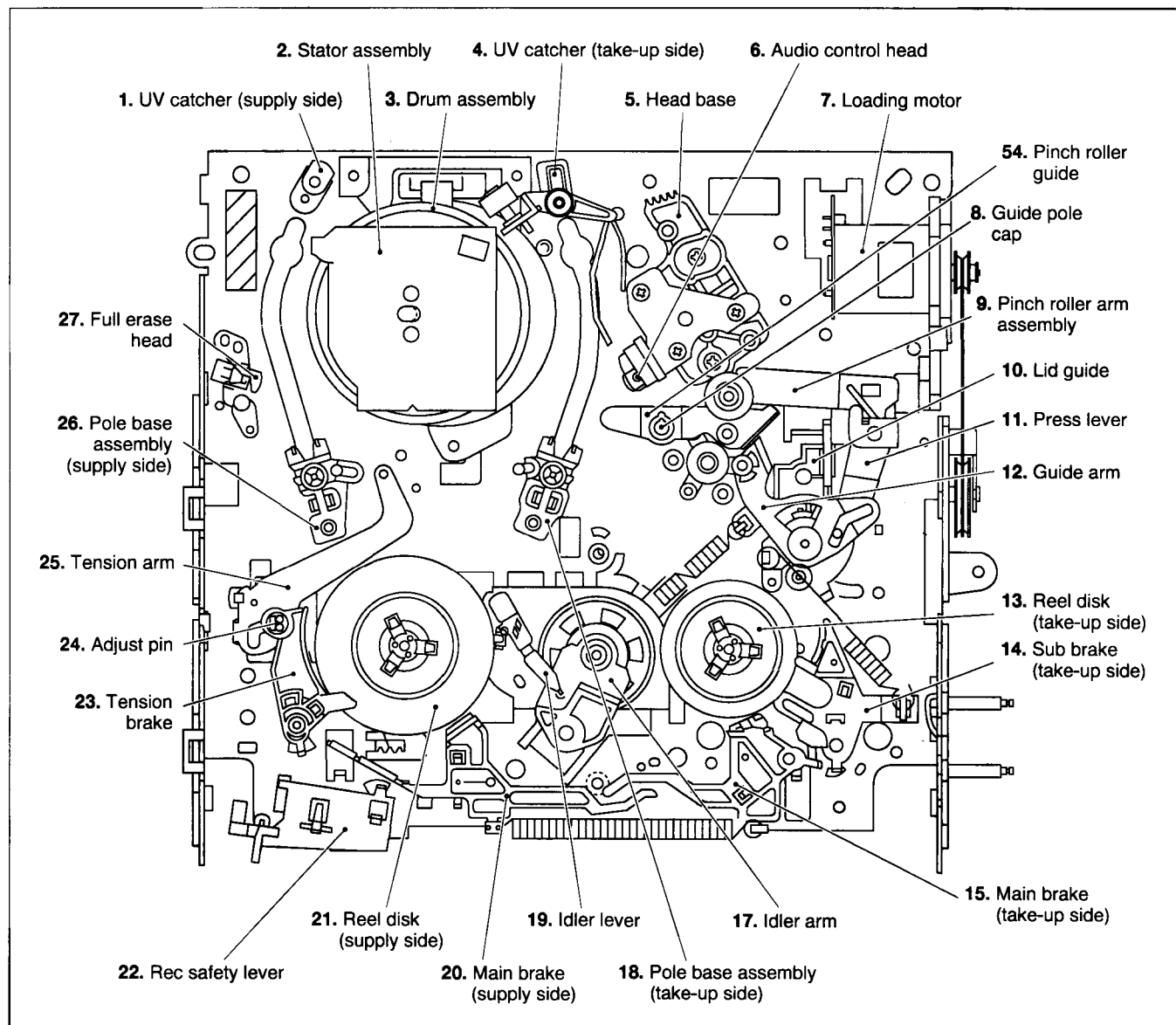


Fig. 2-1-5 Main deck top side

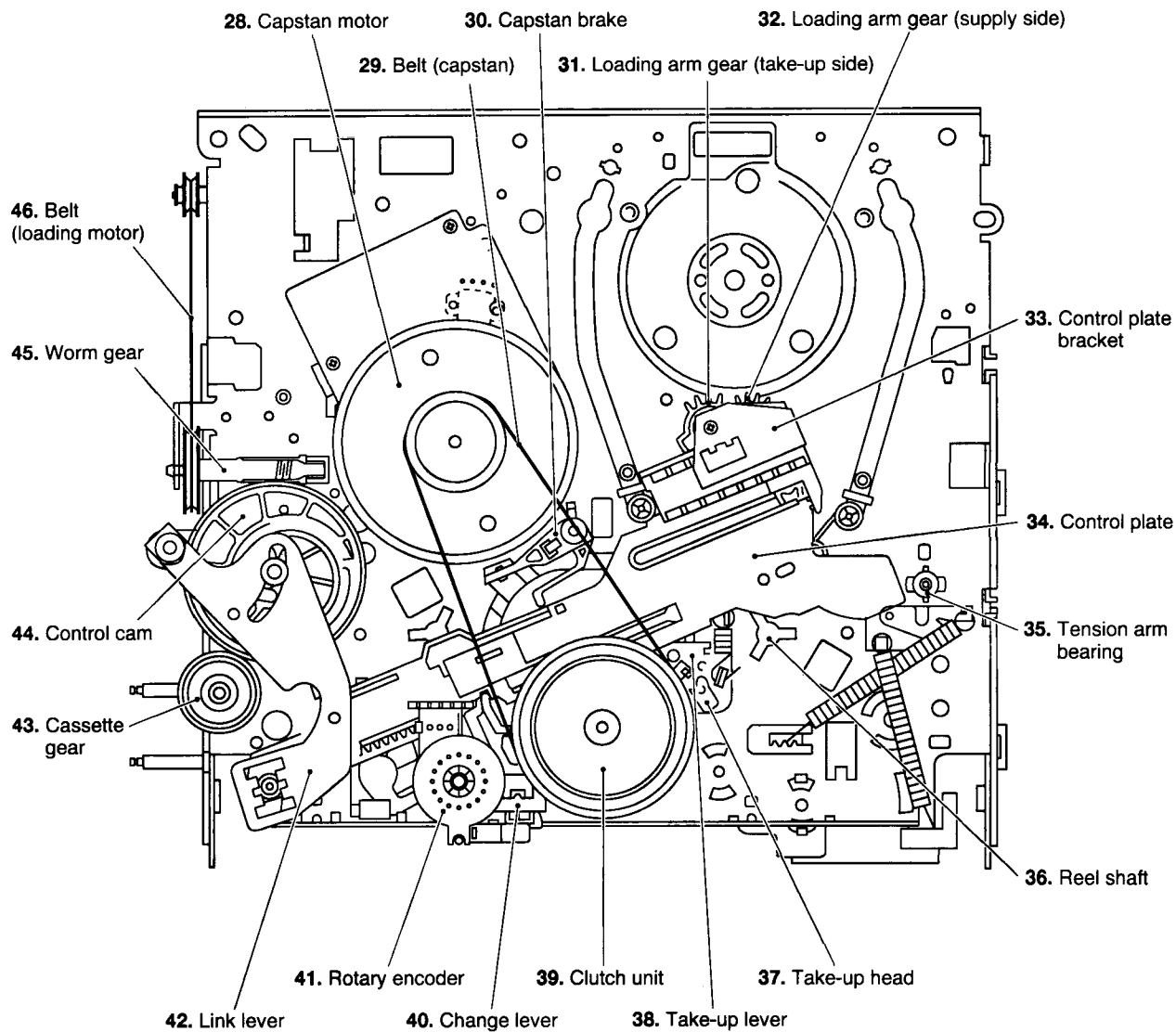


Fig. 2-1-6 Main deck bottom side

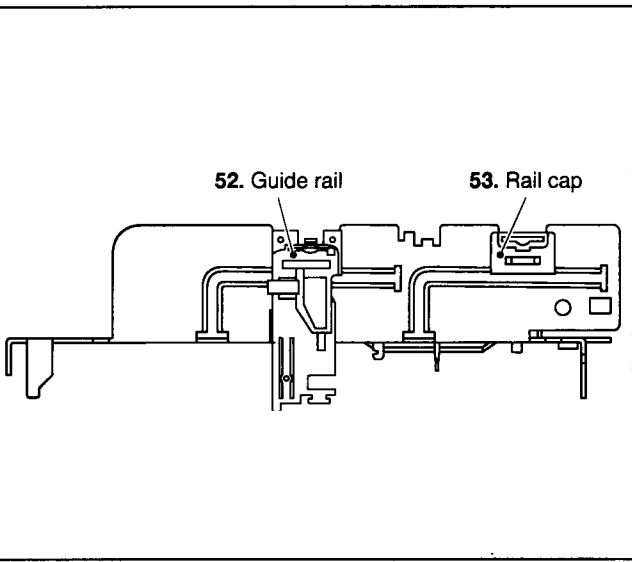


Fig. 2-1-7 Main deck left side

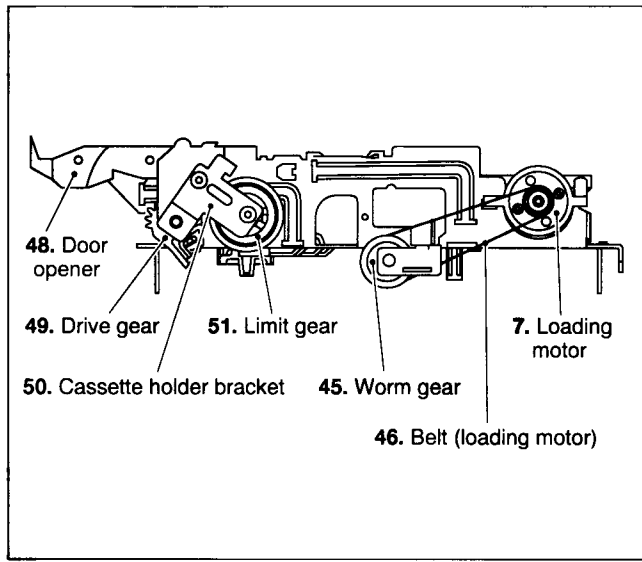


Fig. 2-1-8 Main deck right side

Note: Numerals at the start of the parts names are identical with those of the location diagrams of the major mechanical parts, 1 - 18 of which denote the order of removal. Of the alphabets T and B next to the parts names, T denotes removal from the main deck top side, B from the bottom side and T/B from both sides.

	Replacement parts names		1	4	12	53	46	9	52	11	50	-	-	-	49	32	-	-	38	25	23	31	21	42	41	29	39	40	33	34	14	19	54					
			UV catcher	Guide arm assembly	Rail cap	Belt (loading motor)	Pinch roller arm assembly	Guide rail	Press lever assembly	Cassette Holder bracket	Opener guide	Relay gear	Cassette holder assembly	Drive gear	Loading arm gear (supply side)	Drive arm assembly	Tension spring	Take-up lever	Tension arm assembly	Tension brake assembly	Loading arm gear (take-up side)	Reel base (supply side)	Link lever	Rotary encoder	Belt capstan motor)	Clutch unit	Change lever	Control plate bracket	Control plate	Sub brake	Idler lever	Pinch roller guide						
17	Idler arm	T				1			2		3	4	5	6	7		8					9		10	11	12	13	14	15	16	17		18					
15	Main brake (take-up side)	T/B				1			2		3	4	5	6	7		8								9	10	11	12	13	14	15	16						
13	Reel disk (take-up side)	T				1			2		3	4	5	6	7		8								9	10	11	12	13	14	15	16						
19	Idler lever	T/B				1			2		3	4	5	6	7		8					9		10	11	12	13	14	15	16	17							
-	Rotary encoder guide	T/B				1			2		3	4	5	6	7		8								9	10	11	12	13	14	15	16						
14	Sub brake (take-up side)	T/B				1			2		3	4	5	6	7		8								9	10	11	12	13	14	15							
-	Loading arm gear shaft	B														8							9	1	2	3	4	5	6	7								
35	Tension arm bearing	T				1			2		3	4	5	6				8			9	7																
-	Control plate guide	T/B																	8						1	2	3	4	5	6	7							
37	Take-up head	B																	8						1	2	3	4	5	6	7							
31	Loading arm gear (take-up side)	B														8								1	2	3	4	5	6	7								
25	Tension arm assembly	T/B				1			2		3	4	5	6				8				7																
20	Main brake (supply side)	T/B				1			2		3	4	5	6	7		8																					
38	Take-up lever	T/B																							1	2	3	4	5	6	7							
32	Loading arm gear (supply side)	B																						1	2	3	4	5	6	7								
21	Reel disk (supply side)	T				1			2		3	4	5	6	7																							
-	Drive arm assembly	T				1			2		3	4	5	6	7																							
30	Capstan brake	T/B																							1	2	3	4	5	6	7							
34	Control plate	B																							1	2	3	4	5	6								
23	Tension brake assembly	T/B				1			2		3	4	5	6																								
-	Cassette holder assembly	T				1			2		3	4	5																									
-	Direct gear	B																							1	2	3	4										
10	Lid guide	T		1				2	3																													
40	Change lever	B																							1	2	3											
49	Drive gear	T									1	2	3																									
11	Press lever assembly	T		1				2																														
-	Relay gear	T									1	2																										
51	Limit gear assembly	T									1	2																										
26	Pole base assembly (supply side)	T/B		1																																		
18	Pole base assembly (take-up side)	T/B		1																																		
-	Tension spring (Main brake)	T																																				
22	Rec safety lever	T/B																																				
28	Capstan motor	T/B																									1										2	
45	Worm gear	B					1																															
44	Control cam	B																							1													
43	Cassette gear	B																							1													
39	Clutch unit	B																										1										
9	Pinch roller arm assembly	T		1																																		
-	Opener guide	T									1																											
8	Guide pole cap	T																																				
1,4	UV catcher	T																																				
42	Link lever	B																																				
41	Rotary encoder	B																																				
12	Guide arm assembly	T																																				
50	Cassette holder bracket	T																																				
52	Guide rail	T																																				
53	Rail cap	T																																				
7	Loading motor assembly	T																																				
5	A/C head assembly	T																																				
54	Pinch roller guide	T																																				

2. Cleaning

Regular cleaning of the transport system parts is desirable but practically impossible. So make it a rule to carry out cleaning of the tape transport system whenever the machine is serviced.

When the video head, tape guide and/or brush get soiled, the playback picture may appear inferior or at worst disappear, resulting in possible tape damage.

- (1) When cleaning the upper drum (especially the video head), soak a piece of closely woven cloth or Kimu-wipe with alcohol and while holding the cloth onto the upper drum by the fingers, turn the upper drum counterclockwise.

Note: *Absolutely avoid sweeping the upper drum vertically as this will cause damage to the video head.*

- (2) To clean the parts of the tape transport system other than the upper drum, use a piece of closely woven cloth or a cotton swab soaked with alcohol.
- (3) After cleaning, make sure that the cleaned parts are completely dry before using the video tape.

3. Lubrication

With no need for periodical lubrication, you have only to lubricate new parts after replacement. If any oil or grease on contact parts is soiled, wipe it off and newly lubricate the parts.

- (1) See the mechanism assembly and disassembly diagrams (M4) for the lubricating or greasing spots. See Table 2-1-2 for the types of oil or grease to be used.

Type		Symbols on the disassembly diagrams
Grease		AA
Oil		BB

Table 2-1-2 Grease and oil used for the unit

4. Suggested servicing schedule for main components

The following table indicates the suggested period for such service measures as cleaning, lubrication and replacement. In practice, the indicated periods will vary widely according to environmental and usage conditions. However, the indicated components should be inspected when a set is brought for service and the maintenance work performed if necessary. Also note that rubber parts may deform in time, even if the set is not used.

System	Parts Name	Operation Hours	
		~1000H	~2000H
Tape transport	Upper drum assembly	★○	○
	A/C head	★○	★○
	Lower drum assembly	★	★○
	Pinch roller arm assembly	★	★
	Full erase head	★	★
	Tension arm assembly	★	★
	Capstan motor (Shaft)	★	★
	Guide arm assembly	★	★
Drive	Capstan motor		○
	Capstan brake		○
	Main brake		○
	Belt (Capstan)	○	○
	Belt (Loading motor)		○
	Loading motor		○
	Clutch unit		○
	Worm gear assembly		○
	Control plate		○
Other	Brush assembly	★○	★○
	Tension brake	○	○
	Rotary encoder		○

★: Cleaning

○: Inspection or Replacement if necessary

Table 2-1-3

2.2 REPLACEMENT OF MAJOR PARTS

2.2.1 Before Starting Disassembling

This unit is provided with a mechanism assembly mode. It is therefore necessary to enter this mode for assembling and disassembling procedures.

This mode is usually not in use, manually set it when it is required.

2.2.2 How to Set the Mechanism Assembling Mode

Remove the main deck assembly and place it bottom side up. (See SECTION 1 DISASSEMBLY). Turn the worm gear toward the front so that the register hole of the control cam is brought into alignment with the hole at the main deck assembly chassis. This position renders the mechanism assembling mode operational. Make sure that the control plate is located in alignment with the mark E. (See Fig.2-2-1)

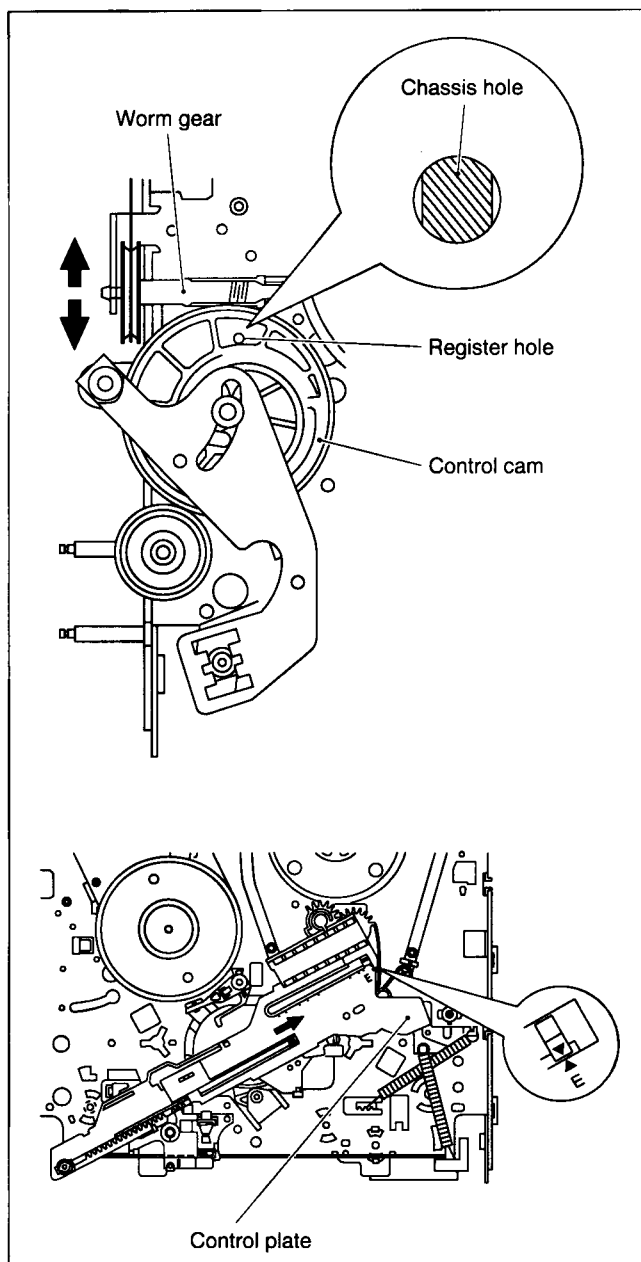


Fig. 2-2-1

2.2.3 Cassette Holder Assembly

1. How to remove

- (1) Remove the guide rail and rail cap. (See Fig.2-2-2).
(2 lugs on the guide rail and one lug on the rail cap)

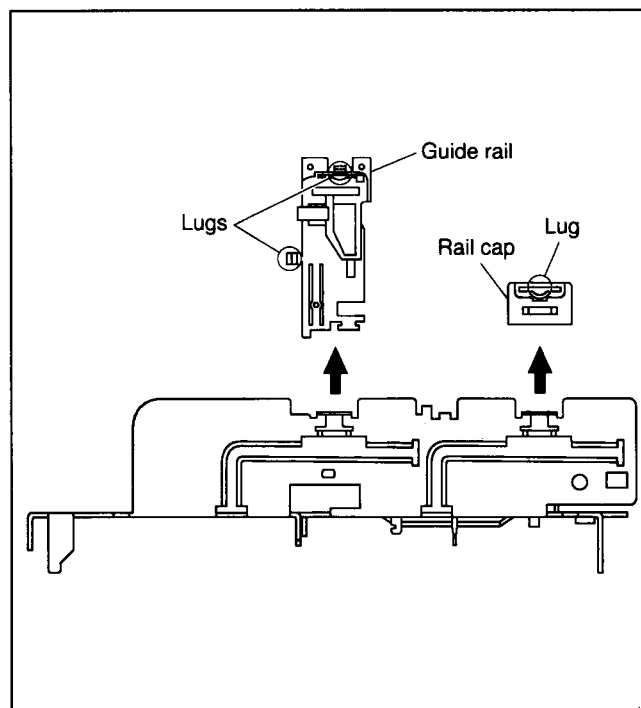


Fig. 2-2-2

- (2) Remove the two slit washers and remove the cassette holder bracket. (See Fig.2-2-3)
- (3) Remove the opener guide, relay gear and limit gear. (See Fig.2-2-3)

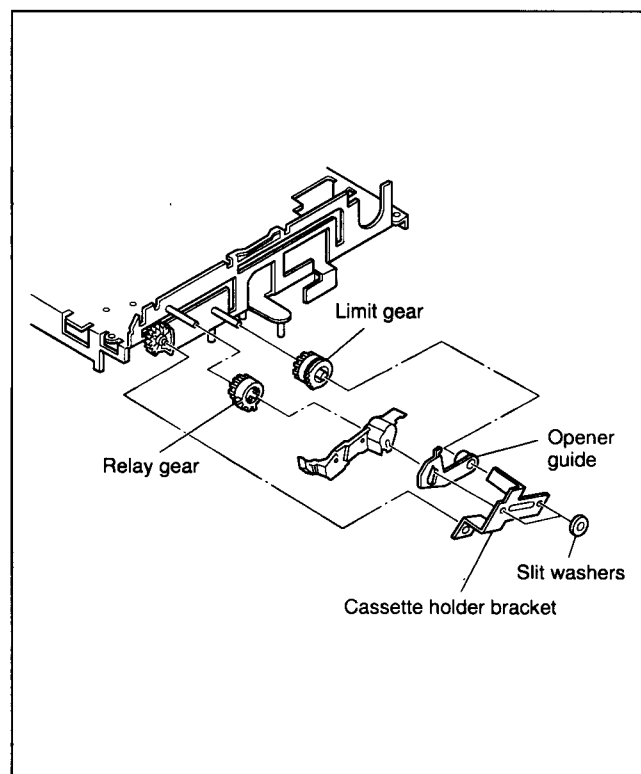


Fig. 2-2-3

(4) While swinging the lock levers (R) and (L) of the cassette holder assembly toward the front, slide the cassette holder assembly until its legs come to where the guide rail and the rail cap have been removed (so that the drive arm is upright). (See Fig.2-2-4)

(5) While holding the left side of the cassette holder, lift the cassette holder assembly so that the three legs on the left side are all released. Then pull the legs (A) and (B) on the right side out of the rail and also pull up the leg (C). (See Fig.2-2-5, Fig.2-2-6)

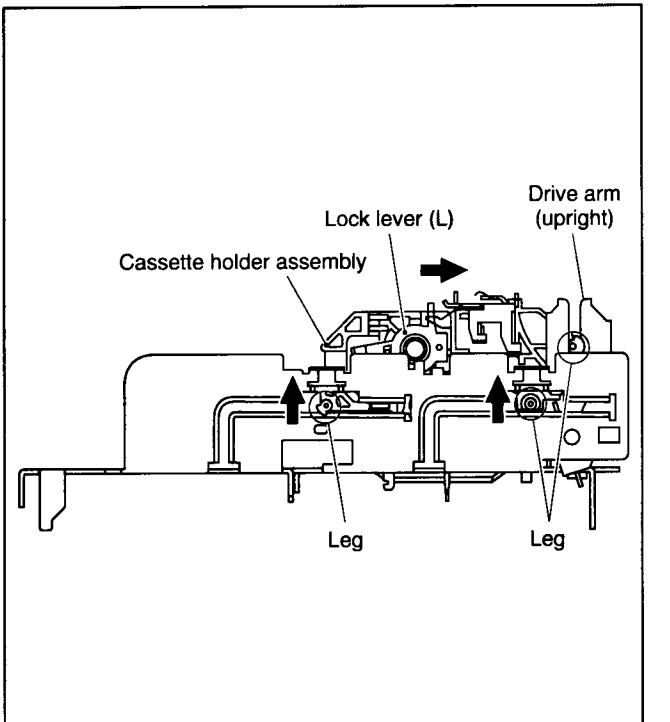


Fig. 2-2-4

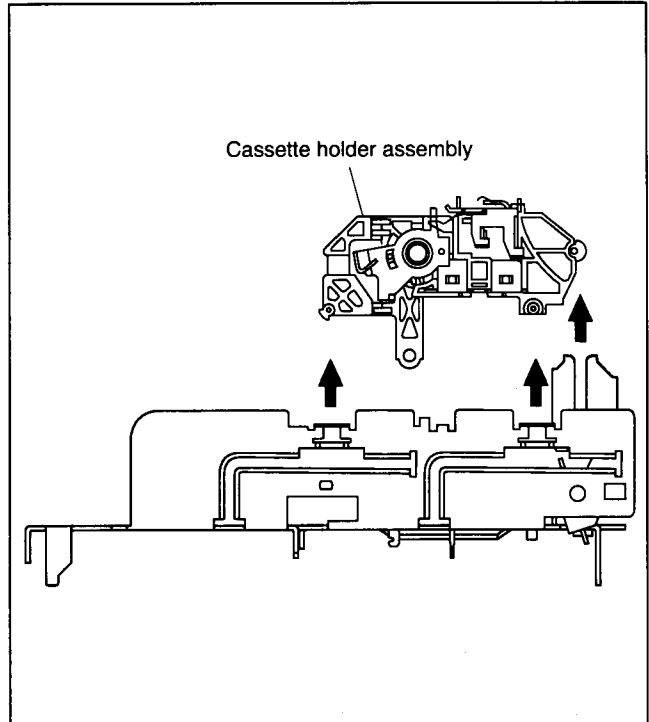


Fig. 2-2-5

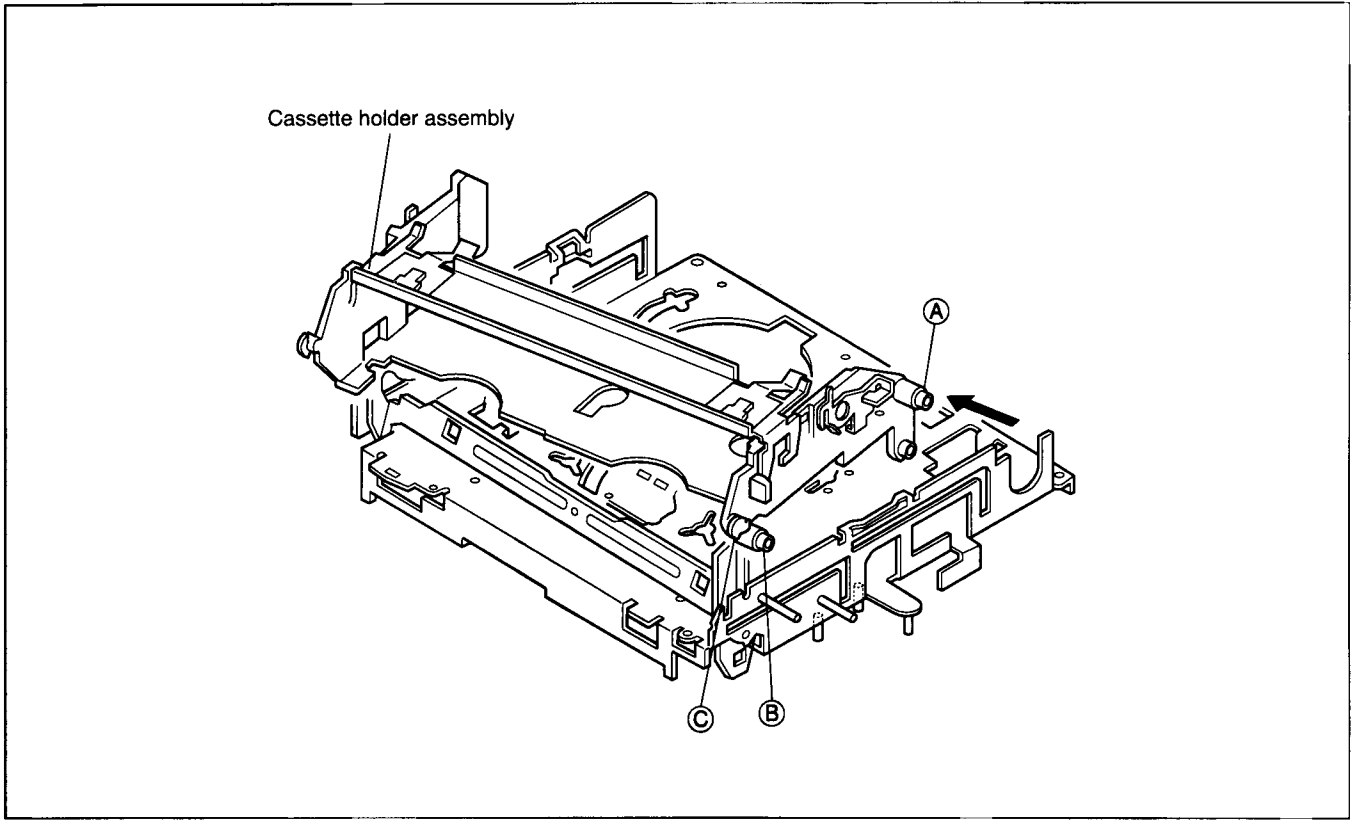


Fig. 2-2-6

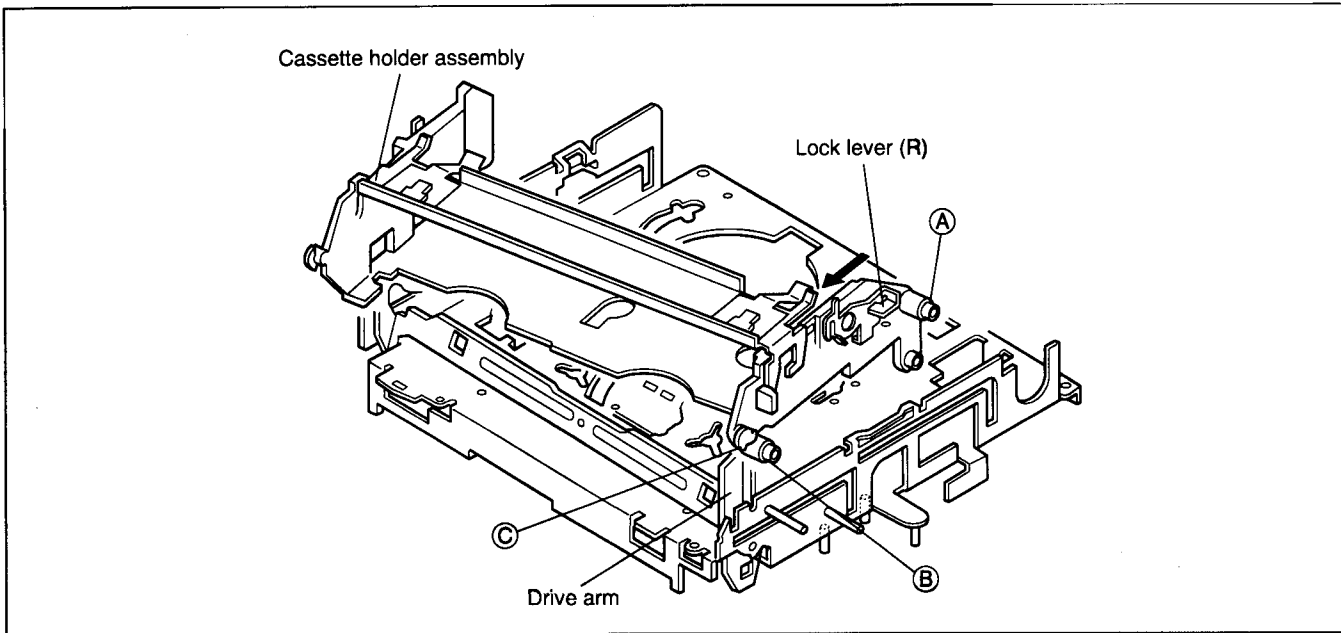


Fig. 2-2-7

2. How to install

- (1) Hold the drive arm upright and fit the leg © on the right side of the cassette holder assembly into the groove. (See Fig.2-2-7)
- (2) While swinging the lock lever (R) of the cassette holder assembly toward front, put the legs (A) and (B) into the rail. (See Fig.2-2-7)
- (3) Drop the three legs on the left side of the cassette holder into the groove at one time. (See Fig.2-2-8)
- (4) Slide the whole cassette holder toward the front to bring it to the eject end position.
- (5) Install the limit gear so that the notch on the outer circumference of the limit gear is brought into alignment with the register hole on the main deck. (See Fig.2-2-9)
- (6) Install the relay gear so that the notch on the outer circumference of the relay gear is brought into alignment with the notch on the main deck. It is important at this stage that the register hole at the limit gear, the register hole at the relay gear and the register hole at the drive gear are all in alignment. (See Fig.2-2-9).
- (7) Install the door stopper, opener guide and cassette holder bracket and fasten the two slit washers.

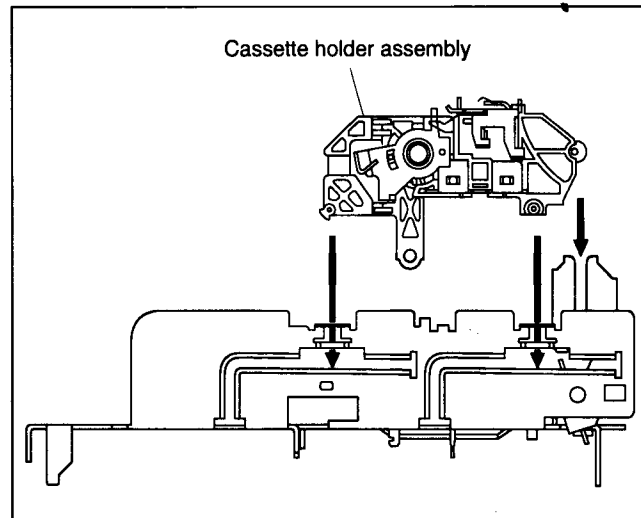


Fig. 2-2-8

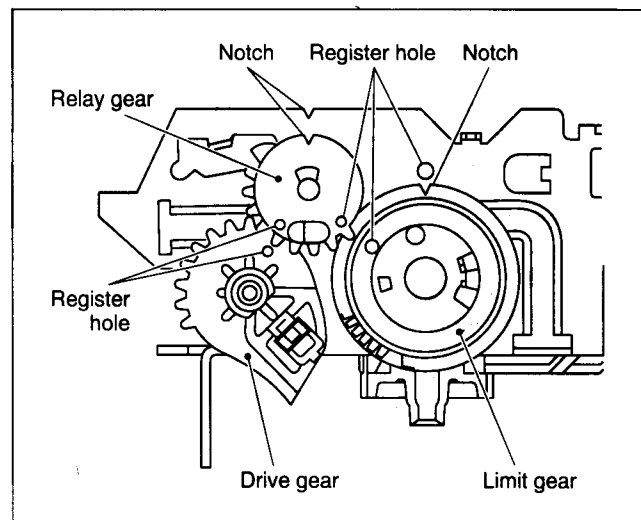


Fig. 2-2-9

2.2.4 Pinch Roller Arm Assembly

1. How to remove

- (1) Remove the spring from the hook of the press lever.
- (2) Remove the slit washer and remove the pinch roller seat.
(See Fig.2-2-10)
- (3) Remove the pinch roller arm assembly by pulling it up.

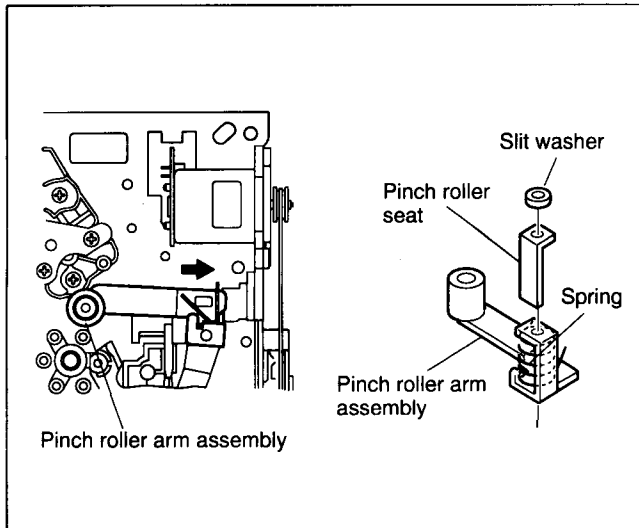


Fig. 2-2-10

2.2.5 Guide Arm and Press Lever

1. How to remove

- (1) Remove the spring and expand the lug of the lid guide in the arrow-indicated direction. Then remove the guide arm by pulling it up.
- (2) Remove the press arm by pulling it up. (See Fig.2-2-11)

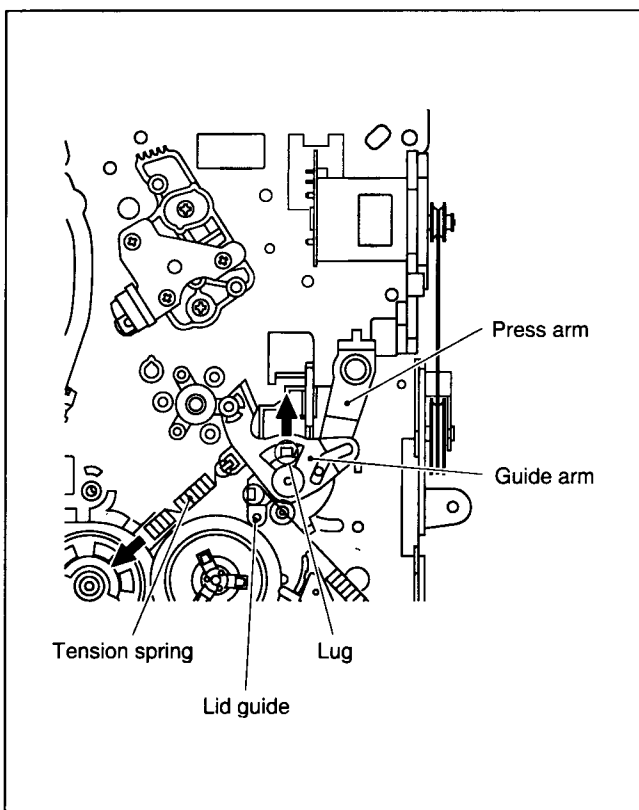


Fig. 2-2-11

2.2.6 Audio Control Head

1. How to remove

- (1) Remove two screws (A) and remove the audio control head together with the head base.

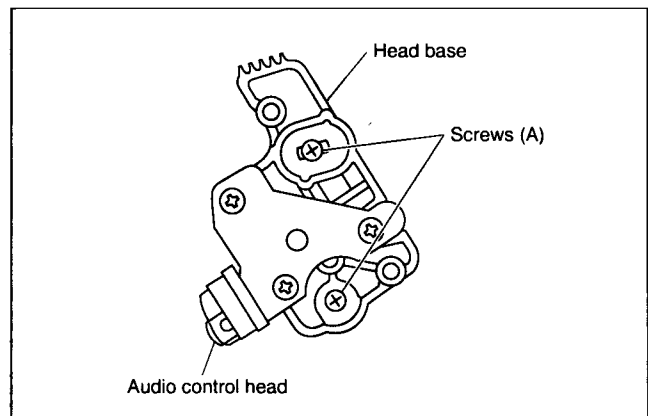


Fig. 2-2-12

- (2) When replacing only the audio control head, remove the three screws (B) while controlling the compression spring.

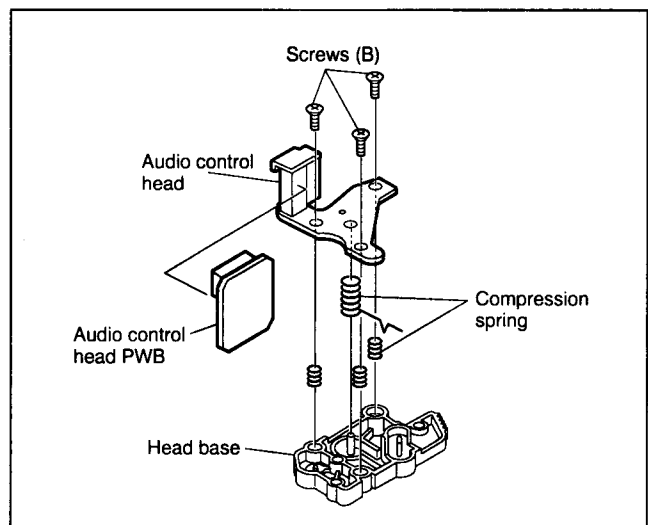


Fig. 2-2-13

2. How to install

- (1) To make the post-installation adjustment easier, set the temporary level as indicated in Fig.2-2-14. Also make sure that the screw center is brought into alignment with the center position of the slot.

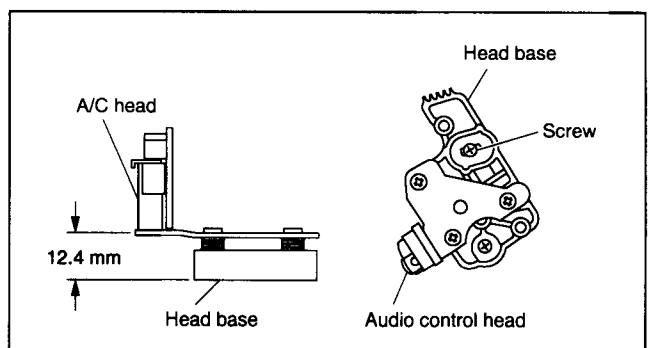


Fig. 2-2-14

2.2.7 Loading Motor

1. How to remove

- (1) Remove the belt wound around the worm gear.
- (2) Open the two lugs of the motor guide and remove the loading motor, loading motor PWB and motor guide altogether by pulling them up.
- (3) When replacing the motor base, take care with the orientation of the motor (so that the label faces upward).
- (4) When the motor pulley has been replaced, choose the fitting dimension as indicated in Fig.2-2-15.

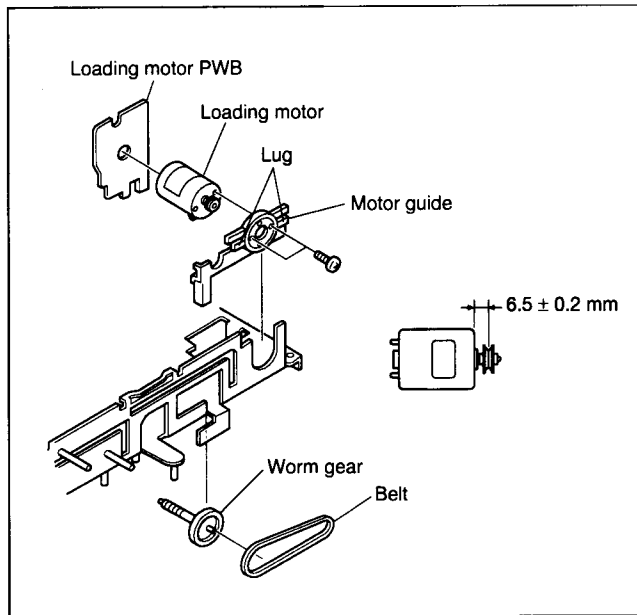


Fig. 2-2-15

2.2.8 Capstan Motor

1. How to remove

- (1) Remove the belt (capstan) on the main deck back side.
- (2) Remove three screws (A) and remove the capstan motor.

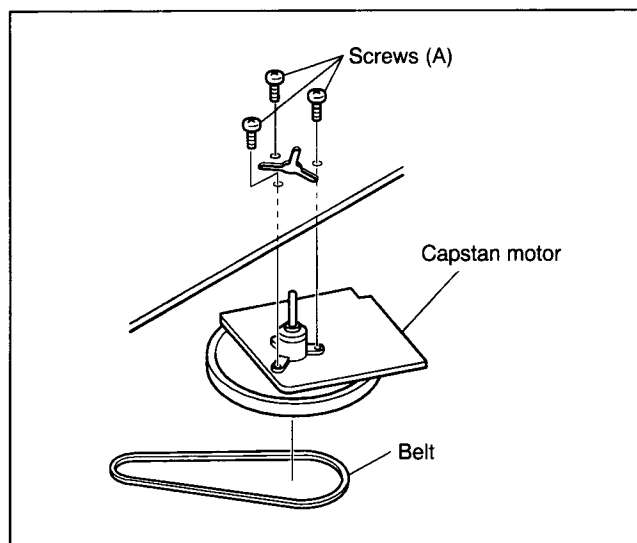


Fig. 2-2-16

2. How to install

Please refer to page 2-25.

2.2.9 Pole Base (on the supply or take-up side)

1. How to remove

- (1) Remove the UV catcher on the removal side by loosening one screw (A).
- (2) Remove the pole base on the supply side from the main deck by loosening one screw (B) on the main deck back side and sliding the pole base toward the UV catcher.
- (3) As for the pole base on the take-up side, turn the pulley of the loading motor to lower the cassette holder because the screw (B) is hidden under the control plate (See the "Procedures for Lowering the Cassette holder assembly" on page 1-3 of 1.3 DISASSEMBLY/ASSEMBLY METHOD). Further turn the motor pulley to move the cassette holder until the screw (B) is no longer under the control plate (in the half-loading position). Then remove it as done for the supply side by removing one screw (B).

NOTE: After reinstalling the Pole base and the UV catcher, be sure to perform compatibility adjustment.

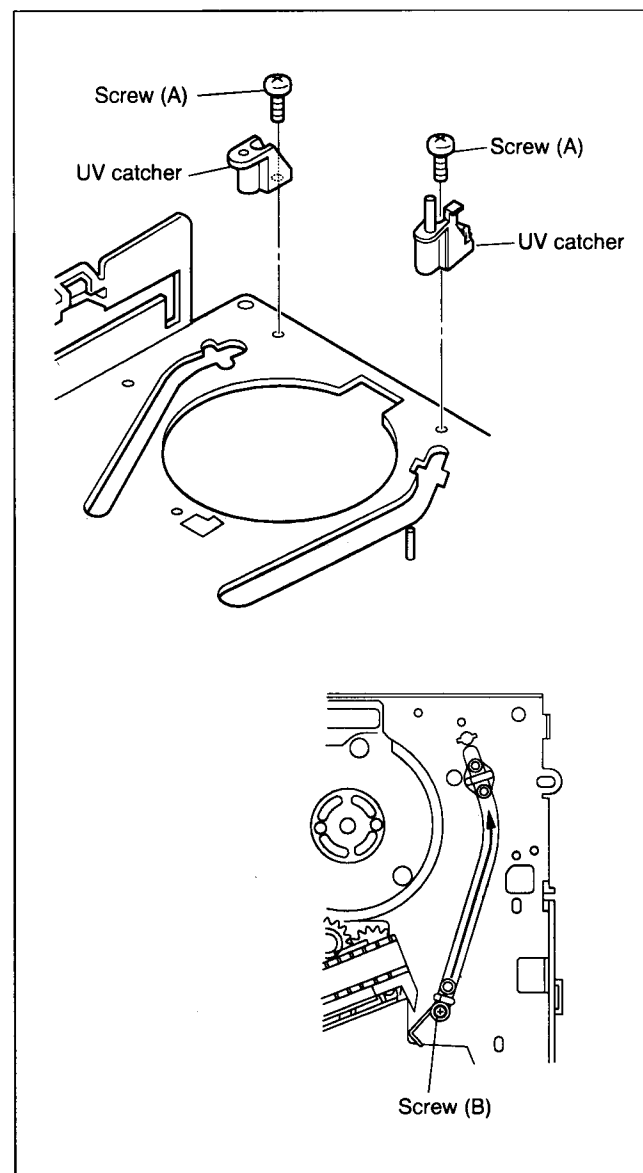


Fig. 2-2-17

2.2.10 Rotary Encoder

- (1) Remove one screw (A) and remove the rotary encoder by pulling it up.
- (2) When installing the rotary encoder, bring the register marks into alignment as indicated in Fig.2-2-18.

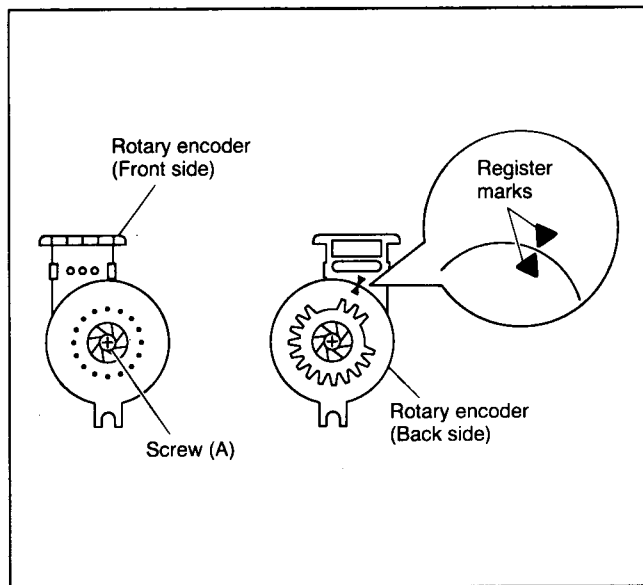


Fig. 2-2-18

2.2.11 Clutch Unit

- (1) Remove the belt wound around the capstan motor and the clutch unit.
- (2) Remove the slit washer and remove the clutch unit.

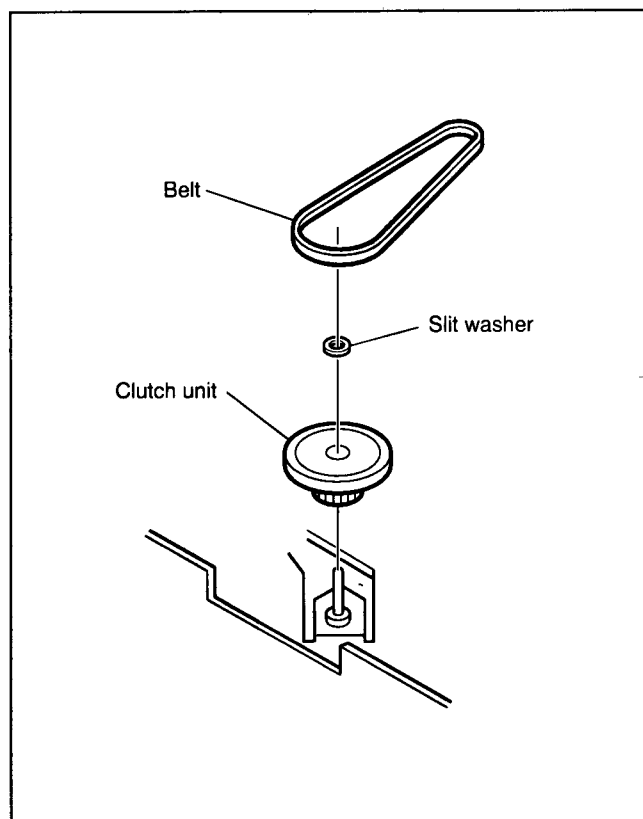


Fig. 2-2-19

2.2.12 Change Lever and Direct Gear

- (1) Release two lugs of the rotary encoder guide in the arrow-indicated direction and remove the change lever.
 - (2) Remove the slit washer retaining the direct gear and remove the latter.
- Take care of the two washers and one spring on and under the direct gear. (See Fig.2-2-20)

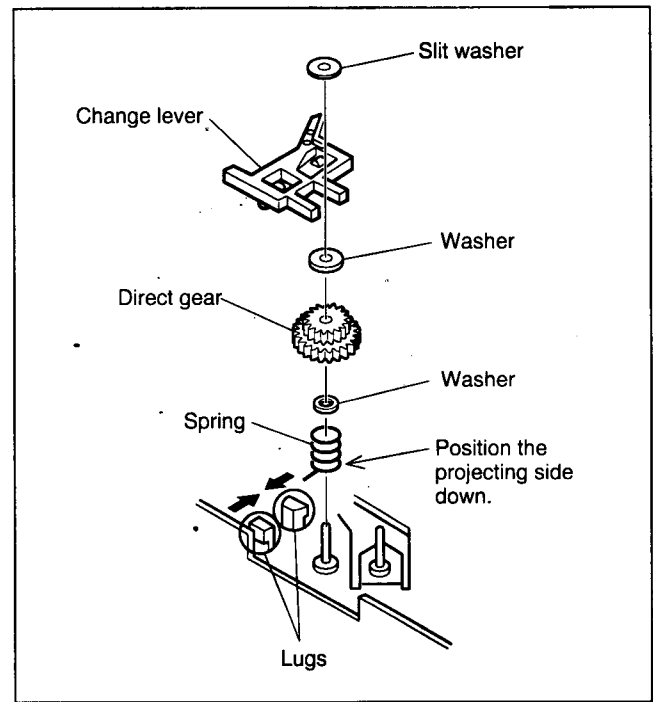


Fig. 2-2-20

2.2.13 Link Lever

- (1) Remove the two slit washers.
- (2) Remove the link lever by lifting it from the shaft retained by the slit washers. Then swing the link lever counterclockwise and remove it from the lock member of the control plate.

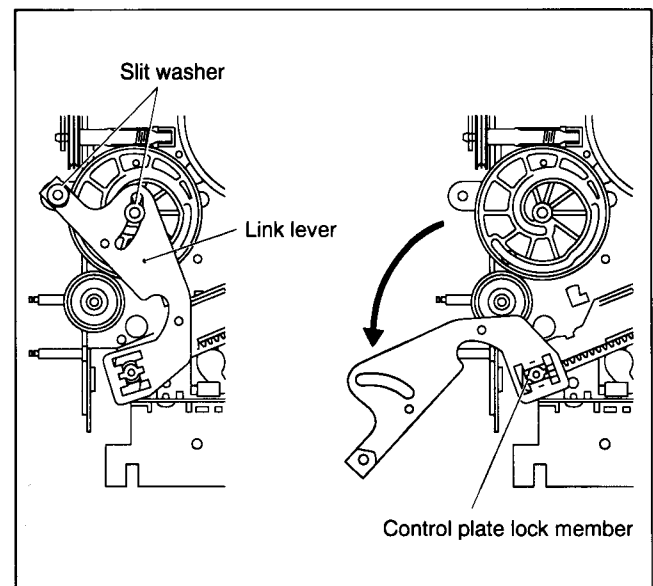


Fig. 2-2-21

2.2.14 Cassette Gear, Control Cam and Worm Gear

- (1) Remove the control cam by lifting it.
- (2) Open the two lugs of the cassette gear outward and pull the latter off.
- (3) Remove the belt wound around the worm gear and the loading motor.
- (4) Open the lug of the lid guide outward and remove the worm gear.
- (5) When installing the control cam, make sure that the register hole at the control cam is in alignment with the register hole of the main deck. (See Fig.2-2-22)

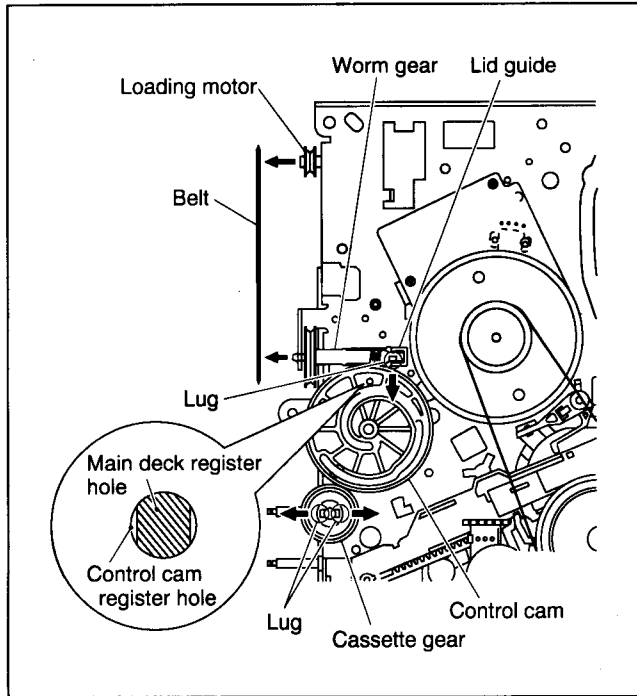


Fig. 2-2-22

2. How to install

- (1) Adjust the position of the idler arm pin as indicated in Fig.2-2-24. (to the left of center of the R section)
- (2) Bring the positioning hole of the take-up lever into alignment with the hole at the control plate guide and fix the position by inserting a 1.5 mm hexagonal wrench.
- (3) Press-fit the pole base (on the supply side) as indicated by the arrow and install the control plate so that section A of the loading arm gear shaft fits into hole (A) of the control plate, section B of the control plate guide into hole (B), and the control plate comes under section C of the rotary encoder guide and section D of the loading arm (on the take-up side). Then slide the whole control plate in the arrow-indicated direction. (See Fig.2-2-25).
- (4) Make sure that the mark E of the control plate is in alignment with the mark ▼ of the loading arm gear shaft. (See Fig.2-2-25)
- (5) Pull off the hexagonal wrench for positioning.

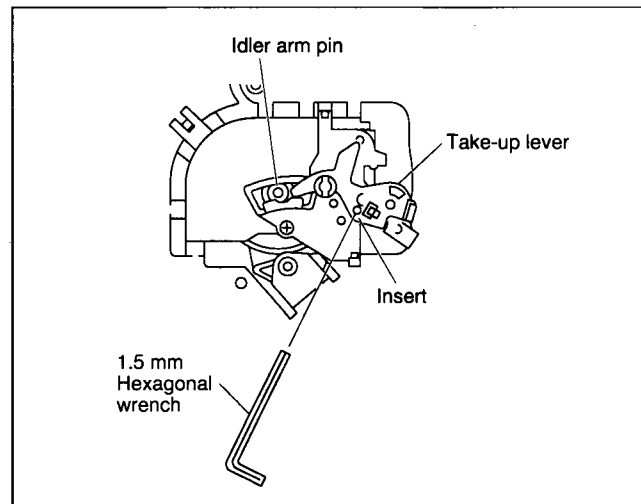


Fig. 2-2-24

2.2.15 Control Plate

1. How to remove

- (1) Remove one screw (A) retaining the control plate bracket and remove the latter.
- (2) Slide the control plate as indicated by the arrow and remove the control plate. (See Fig.2-2-23)

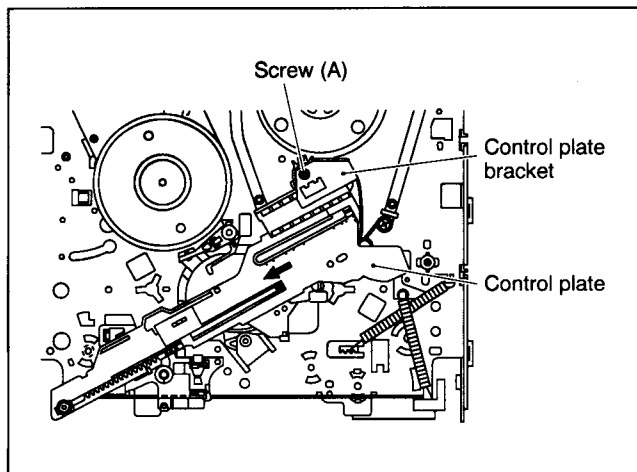


Fig. 2-2-23

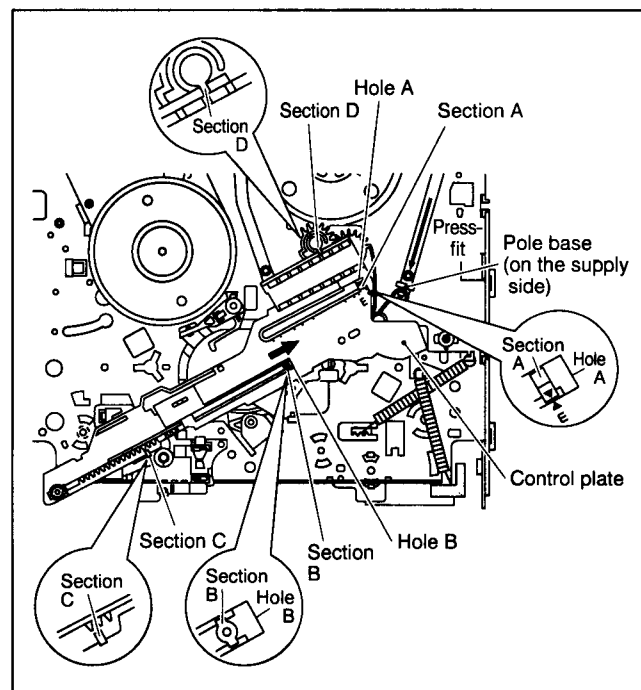


Fig. 2-2-25

2.2.16 Loading Arm (on the supply or take-up side) and Loading Arm Gear Shaft

1. How to remove

- (1) Remove the loading arm (on the supply side) by loosening screw (A) in Fig.2-2-26.
- (2) Remove screw (B) in Fig.2-2-26 and slide the pole base in the loading direction with the spring held on the pole base (on the take-up side). (See Fig.2-2-26)
- (3) Pull the spring out of the pole base. Turn the loading arm clockwise through about 45 degrees so that the notch of the loading arm is in alignment with the projection of the loading arm gear shaft and lift it. Likewise, turn the loading arm counterclockwise through 180 degrees so that the notch is in alignment with the projection and remove the loading arm (on the take-up side). (See Fig.2-2-27)
- (4) When removing the loading arm gear shaft, be sure of first removing the screw retaining the drum assembly (on the back side of the loading arm gear shaft). Then remove one screw (C) and remove the loading arm gear shaft by sliding it in the arrow-indicated direction.

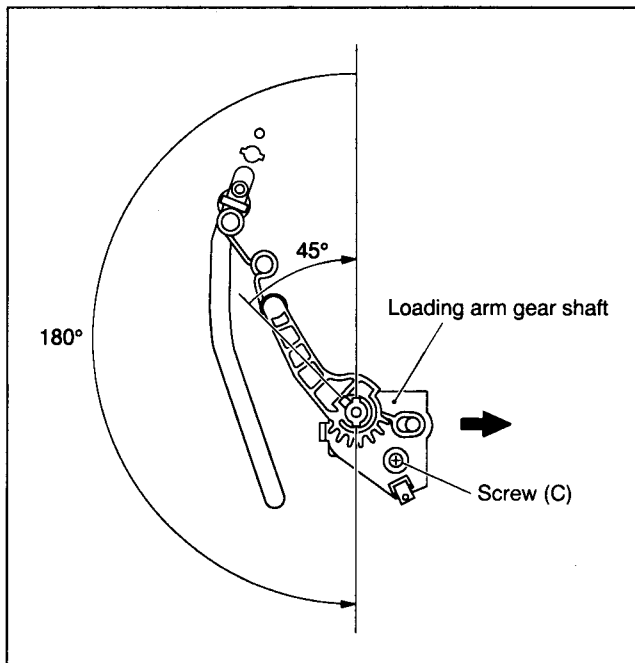


Fig. 2-2-27

2. How to install

- (1) Install the loading arm (on the take-up side) as indicated in Fig.2-2-28 and turn it clockwise through 180 degrees so that the loading arm reaches the bottom of the loading arm gear shaft.
- (2) Then turn the loading arm (on the take-up side) counterclockwise through 180 degrees. Hang the spring on the pole base and tighten the screw.
- (3) Install the loading arm (on the supply side) so that the register mark of the loading arm (on the take-up side) is in alignment with the register mark of the loading arm (on the supply side). Then hang the spring on the pole base and tighten the screw. (See Fig.2-2-26).

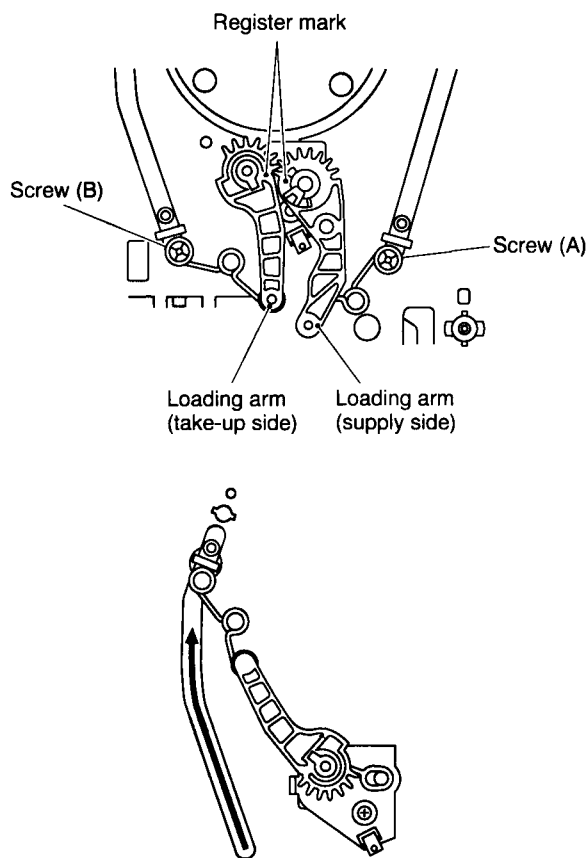


Fig. 2-2-26

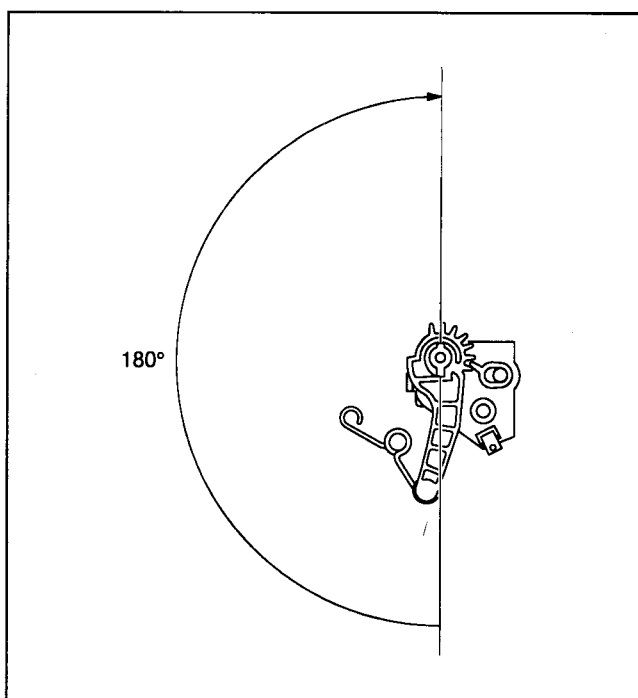


Fig. 2-2-28

2.2.17 Take-up Lever, Take-up Head and Control Plate Guide

- (1) Remove the spring of the take-up lever from the main deck.
- (2) Remove one lug of the take-up lever from the main deck and pull out the take-up lever and the take-up head together.
- (3) Remove one screw (A).
- (4) Remove two lugs of the control plate guide from the main deck. Locate the idler arm pin in the center of the R section of the control plate and remove the latter.

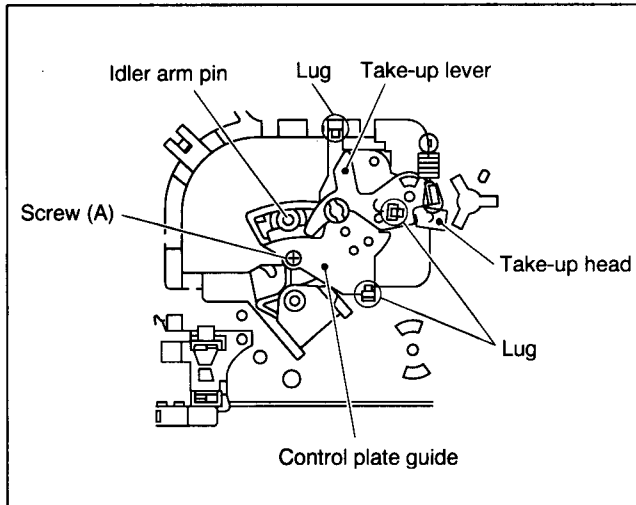


Fig. 2-2-29

2.2.18 Capstan Brake

- (1) Move lug (A) of the capstan brake in the arrow-indicated direction so that it comes into alignment with the notch of the main deck. (See Fig. 2-2-30)
- (2) Remove lug (B) of the capstan brake from the main deck and remove the capstan brake.

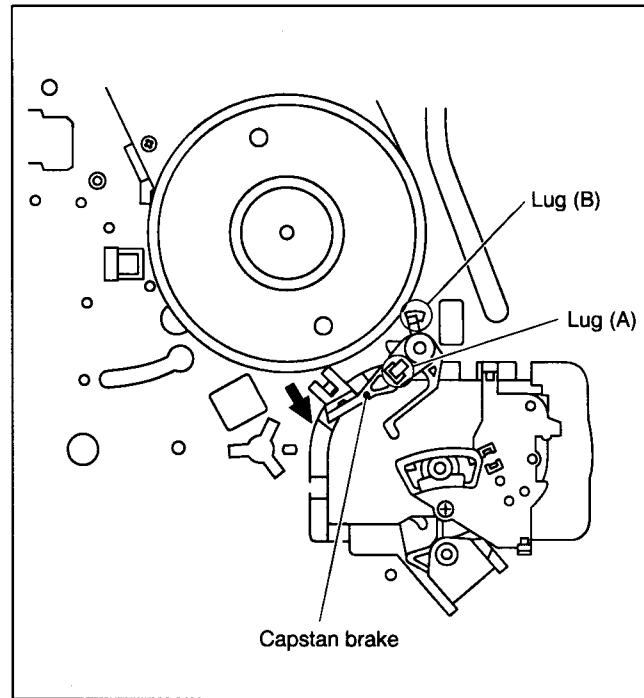


Fig. 2-2-30

2.2.19 Drive Gear and Drive Arm

1. How to remove

- (1) Remove the cassette holder assembly. (See 2.2.3 How to remove the cassette holder assembly)
- (2) Pull out the drive gear and remove the drive arm.

2. How to install

- (1) Insert section ① of the drive arm into section ② of the main deck.
- (2) Insert section ① of drive gear into hole ○ of the drive arm and section ② into hole □. (See Fig. 2-2-31)

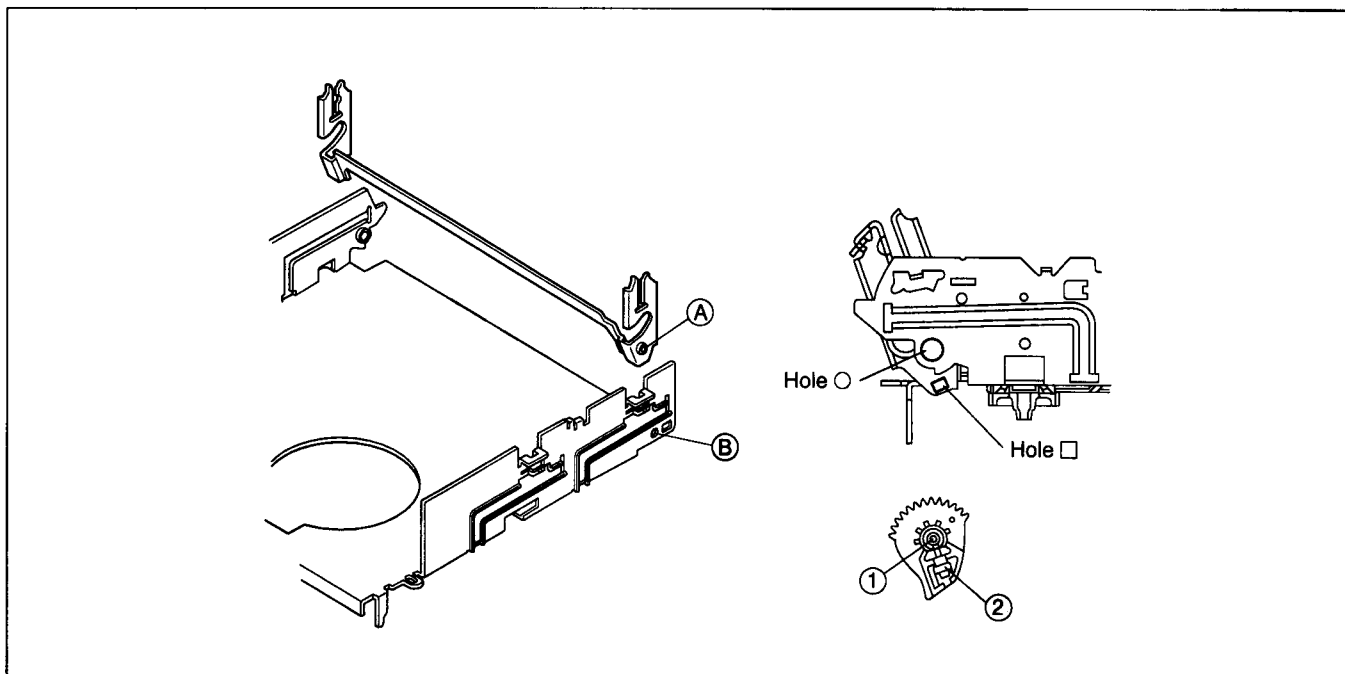


Fig. 2-2-31

2.2.20 Sub Brake (on the take-up side)

- (1) Remove the spring attached to the lid guide and sub brake.
- (2) Bring lug (A) of the sub brake into alignment with the notch of the main deck.
- (3) Remove lugs (B) and (C) of the sub brake from the main deck and remove the sub brake.

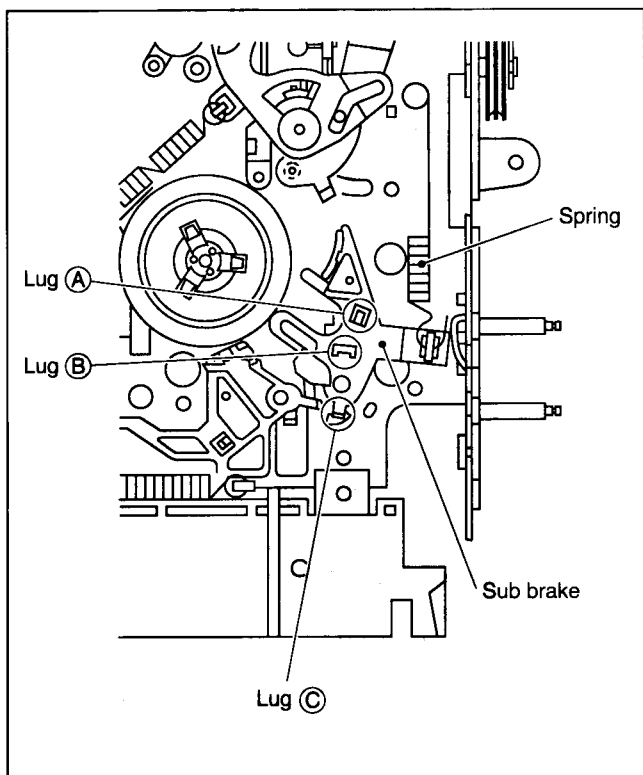


Fig. 2-2-32

2.2.21 Main Brake (on the take-up side), Reel Disk (on the take-up side) and Main Brake (on the supply side)

- (1) Move the main brake (on the take-up side) in the arrow-indicated direction and remove the reel disk (on the take-up side).
- (2) Remove the spring attached to the main brake.
- (3) Remove lug (A) of the main brake (on the take-up side) and pull out lug (B) after bringing it into alignment with the main deck notch.
- (4) Remove lugs (C) and (D) of the main brake (on the supply side) from the main deck and pull them off. (See Fig. 2-2-33)

Note: If the main brake is difficult to remove, press it and hold the adjustment pin from the back side of the main deck when attempting to remove it. After the adjustment pin has been removed or the main brake or the reel disk on the supply or take-up side have been replaced, it is required to adjust the main brake torque. See page 2-24 for the detailed adjustment procedures.

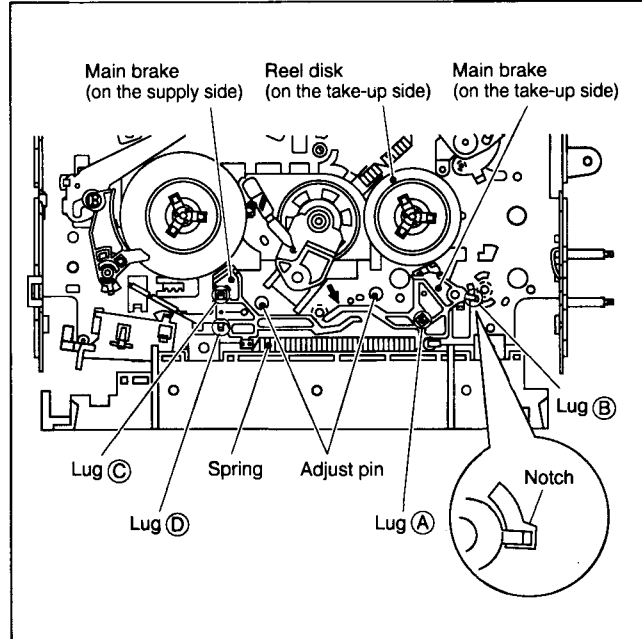


Fig. 2-2-33

2.2.22 Tension Brake, Reel Disk (on the supply side) and Tension Arm

- (1) Remove the three lugs of the tension brake from the main deck and pull them off.
- (2) Remove the reel disk (on the supply side) by loosening in the arrow-indicated direction the main brake (on the supply side).
- (3) Remove the tension spring on the main deck back side and remove the lugs of the tension arm bearing to pull up and remove the tension arm. (See Fig. 2-2-34)

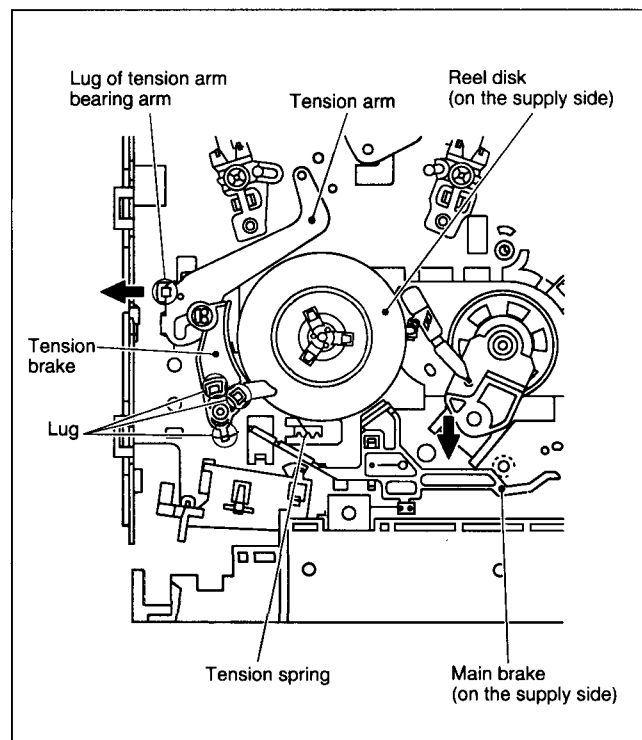


Fig. 2-2-34

2.2.23 Idler Lever, Idler Arm and Reel Shaft

- (1) Remove one lug of the idler lever from the main deck and remove the hook fitted in the idler arm hole by lifting it.
- (2) Remove the slit washer and pull out the idler arm.
- (3) Turn the reel shaft counterclockwise through 60 degrees and remove it. (See Fig.2-2-35)

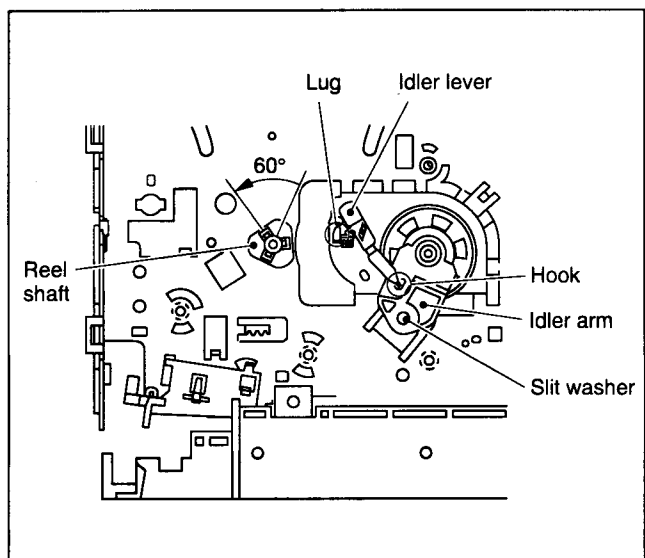


Fig. 2-2-35

2.2.24 Stator Assembly

- (1) Remove two screws (A).
- (2) Remove the stator assembly by lifting in the arrow-indicated direction (Take care that the brush spring does not jump out).
- (3) Remove the flat cable.
- (4) After installation, be sure to perform the 3.2.1 PB switching point adjustment according to the electrical adjustment procedure.

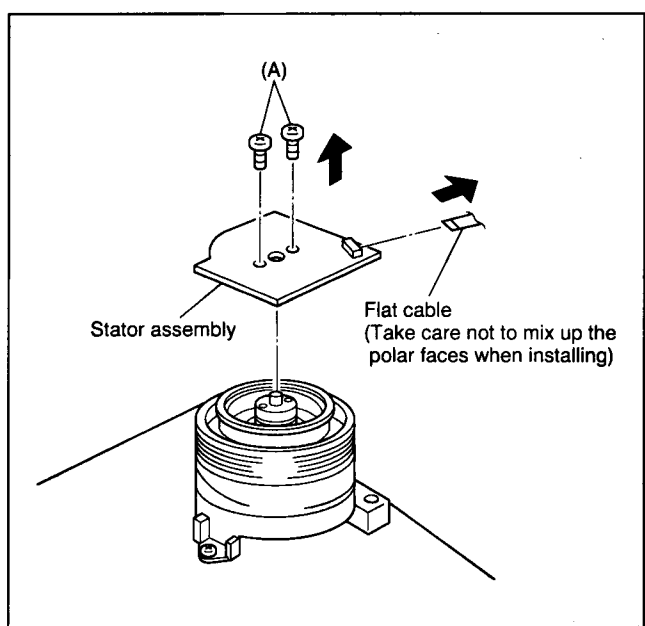


Fig. 2-2-36

2.2.25 Rotor Assembly

- (1) Remove the stator assembly.
- (2) Remove the two screws (B) and remove the rotor assembly.

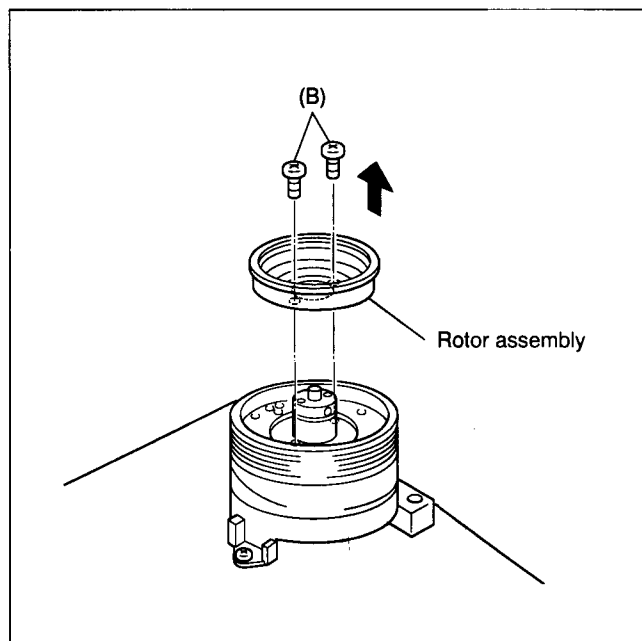


Fig. 2-2-37

Note: When installing the rotor assembly, note that a normal picture cannot be obtained without ensuring the phase matching as mentioned below.

- (3) Match the phases of the upper drum and the rotor assembly as indicated in Fig.2-2-38.
- (4) Place the upper drum hole (a) over the rotor assembly holes (b) (with three holes to be aligned) and tighten the two screws (B). (See Fig.2-2-38)

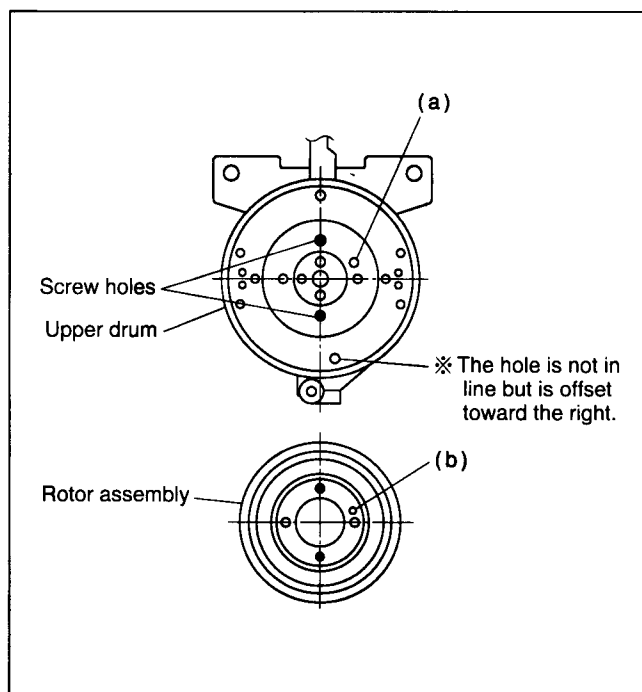


Fig. 2-2-38

2.2.26 Upper Drum Assembly

1. How to remove

- (1) Remove the stator assembly and rotor assembly. (See Fig. 2.2.36 and Fig. 2.2.37)
- (2) Loosen the screw of the collar assembly using a 1.5 mm hexagonal wrench and remove the collar assembly. Also remove the brush, spring and cap at one time.
- (3) Remove the upper drum assembly and remove the washer using tweezers.

Note: When replacement is required, control the up-down movement of the brush. Never apply grease.

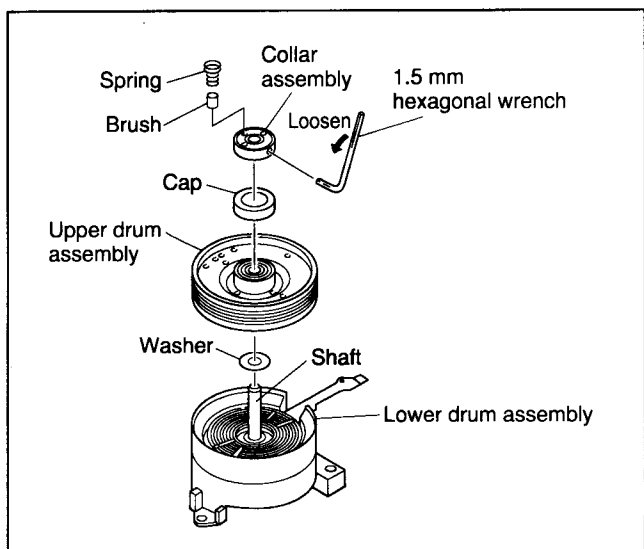


Fig. 2-2-39 Upper drum assembly-1

2. How to install

- (1) Clean coil parts of the lower drum assembly and the newly installed upper drum assembly with an air brush in advance. (See Fig.2-2-40).
- (2) Install a new washer and upper drum assembly on the drum shaft. (See Fig.2-2-39)

Note: When replacing the upper drum assembly, replace it together with the washer.

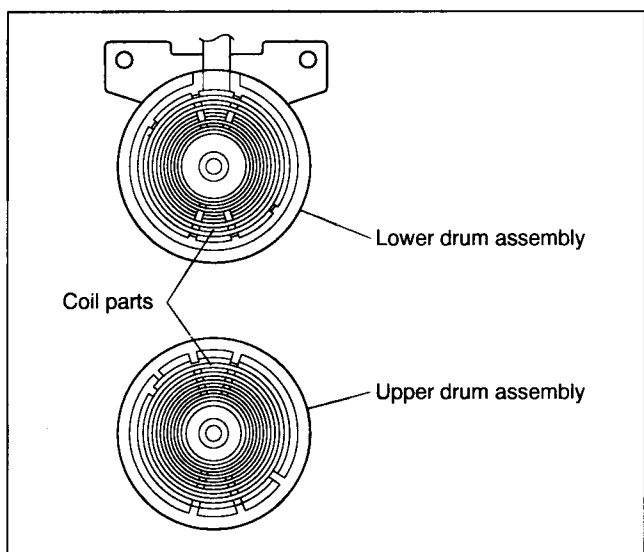


Fig. 2-2-40

- (3) Position the collar assembly as indicated in Fig.2-41 while controlling its up-down movement.

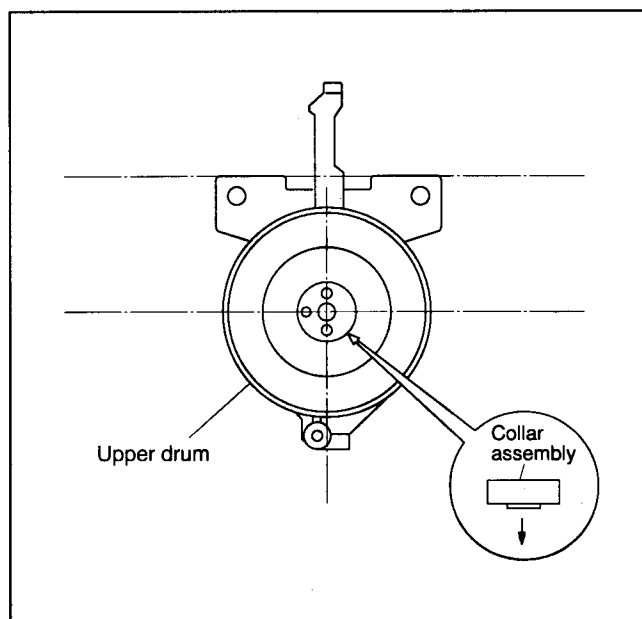


Fig. 2-2-41

- (4) Secure the collar assembly in position with a hexagonal wrench while pressing its top with the fingers.

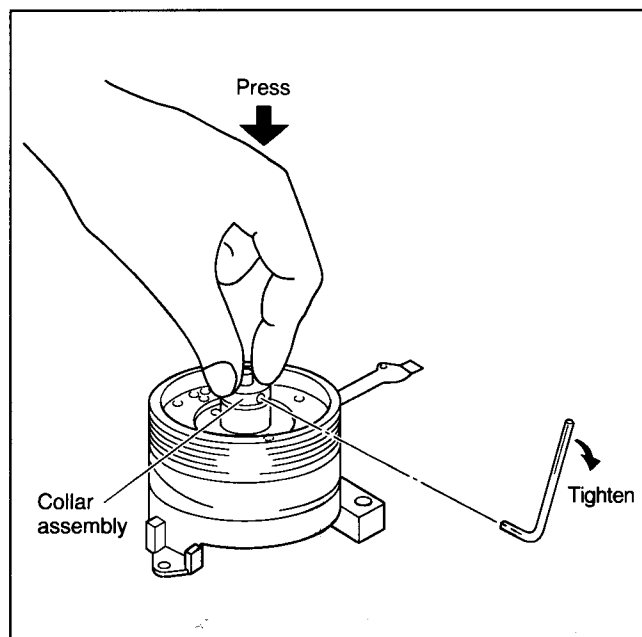


Fig. 2-2-42

- (5) After installation, gently turn the upper drum with your hand to make sure that it turns normally.
- (6) Install the rotor assembly and stator assembly according to Fig. 2.2.36 and Fig. 2.2.38.
- (7) When installation is complete, clean the upper drum assembly and lower the drum assembly and carry out the following adjustments.
 - PB switching point adjustment
 - Slow tracking adjustment
 - Compatibility adjustment (Be sure to check for compatibility for the LP mode.)

2.3 MAJOR PARTS INSTALLATION (PHASE MATCHING BETWEEN MECHANICAL PARTS)

2.3.1 Before Assembly of the Parts

The mechanism of this unit is closely linked with the rotary encoder and system controller circuits.

Since the system controller detects the status of mechanical operation in response to phases of the rotary encoder (internal switch positions), the mechanism may not operate properly unless such parts as the rotary encoder, control plate, loading arm assembly, control cam, cassette gear, limit gear, relay gear and drive gear are installed in their correct positions.

Especially, this model is not provided with any cassette housing assembly, so that cassette loading and unloading must be accomplished by operation of the cassette holder assembly. The latter is in turn driven by such parts as drive gear, relay gear and limit gear. Exercise enough care, therefore, to have the phases of all this gear matching one another.

Perform the installation of major parts (including phase matching) in the mechanism assembling mode as in the previous section.

2.3.2 Loading Arm Assembly (on the Supply or Take-up Side)

- (1) Return the pole base assembly to the foremost position in the unloading direction.
- (2) Install the loading arm assembly so that the register mark on the gear of the supply side loading arm is in alignment with the one on the take-up side loading arm as indicated in Fig. 2-3-1.

See 2.2.16 "2. How to install" of the foregoing section for details of installation.

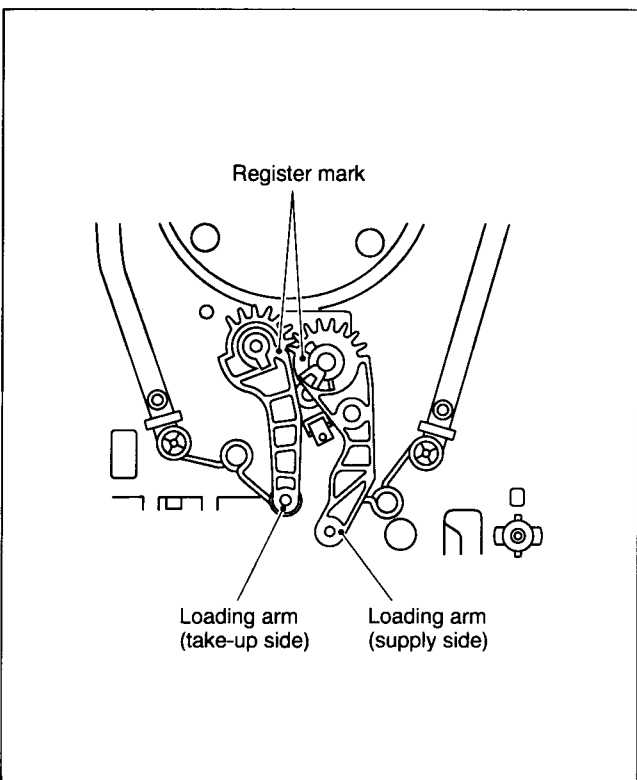


Fig. 2-3-1

2.3.3 Control Plate

- (1) With register marks on the both loading arm assemblies in alignment, install the control plate so that the mark ▼ on the loading arm gear shaft is in alignment with mark E of the control plate. (See Fig.2-3-2)
See 2.2.15 "2. How to install" of the foregoing section for details of installation.

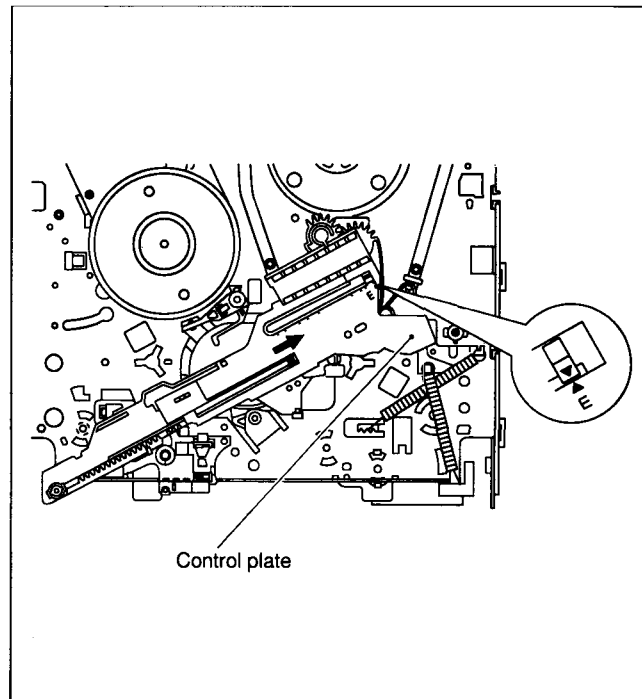


Fig. 2-3-2

2.3.4 Rotary Encoder

- (1) Make sure that the mark E of the control plate is in alignment with the mark ▼ of the loading arm gear shaft and bring the register marks on the rotary encoder into alignment as indicated in Fig.2-3-3.
- (2) Turn over the rotary encoder with its register marks kept in alignment and install it by fitting on the shaft of the rotary encoder guide and the positioning pin.
- (3) Tighten the screw (A) to complete the installation.

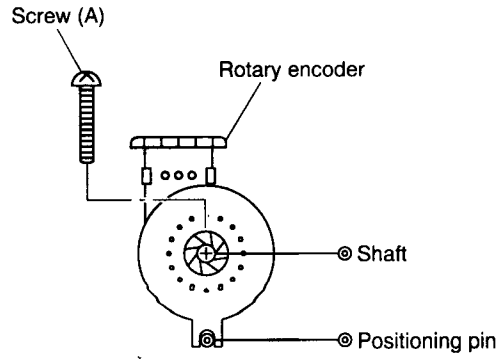
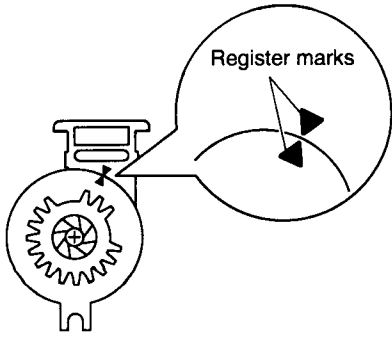


Fig. 2-3-3

2.3.5 Control Cam, Cassette Gear and Link Lever

- (1) Install the control cam as indicated in Fig.2-3-4 making sure of the front and back side alignment. Note here that the register hole of the control cam is in alignment with and allows passage through the register hole of the main deck. Perform fine-adjustment by turning the worm gear.
- (2) Install the cassette gear by pushing it until it is locked with a clicking sound. (See Fig.2-3-4)
- (3) Insert section (A) of the link lever into section (B) of the control plate as shown in Fig.2-3-5.

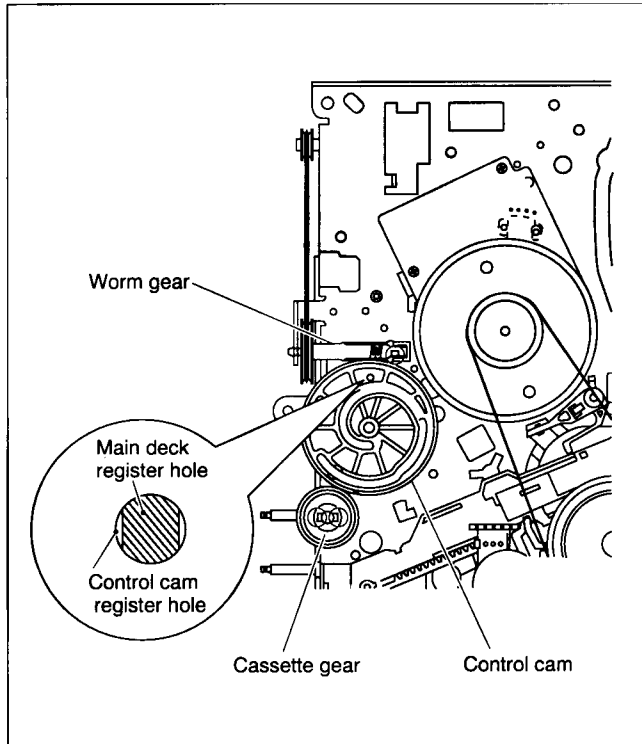


Fig. 2-3-4

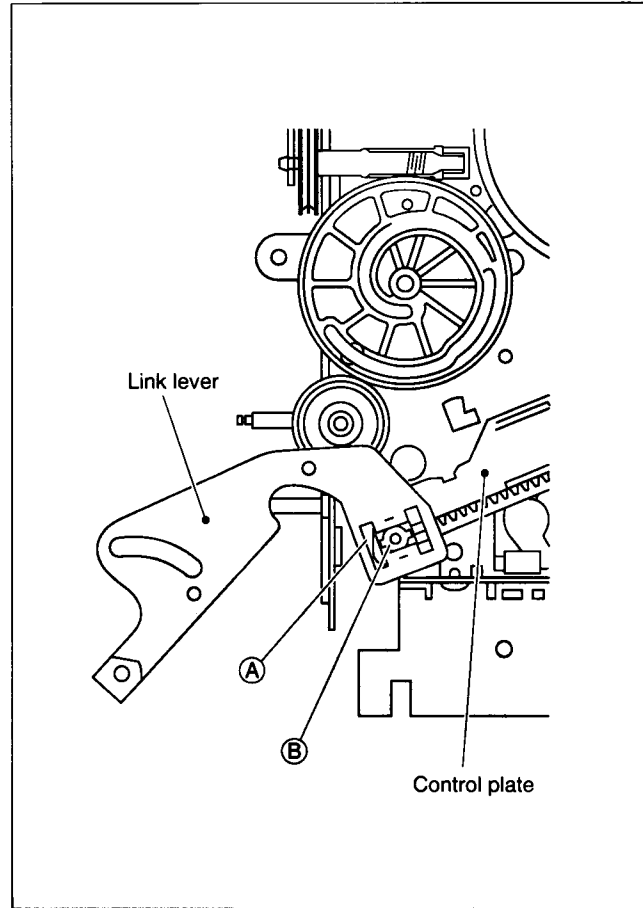


Fig. 2-3-5

- (4) Turn the link lever clockwise and mount it on the control cam center shaft (A) and the control cam left-side shaft (B). (See Fig.2-3-6).

- (5) Fasten the slit washers at two points (A) and (B).

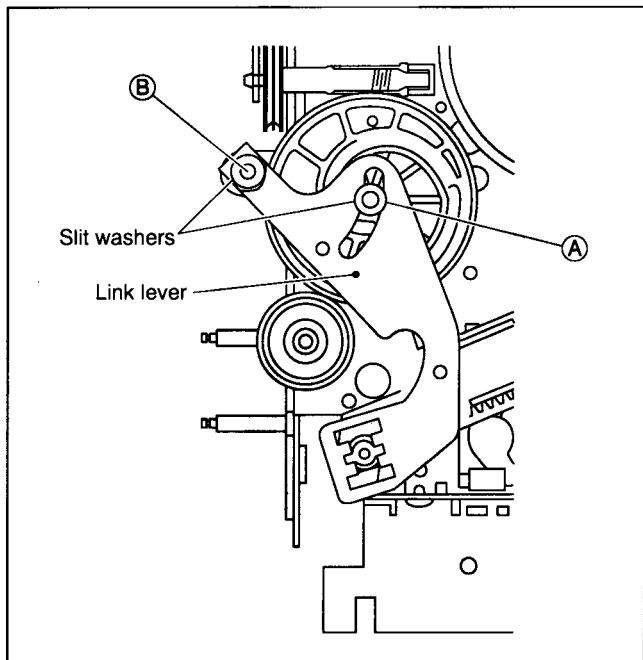


Fig. 2-3-6

2.3.6 Relay Gear, Limit Gear and Drive Gear

- Install the limit gear so that the notch at its outer circumference is in alignment with the register hole of the main deck. (See Fig.2-3-7)
- Install so that the notch at the outer circumference of the relay gear is in alignment with the notch of the main deck, and at the same time, that the hole A of the relay gear is in alignment with hole A of the limit gear and hole B of the relay gear with hole B of the drive gear. (See Fig.2-3-7)

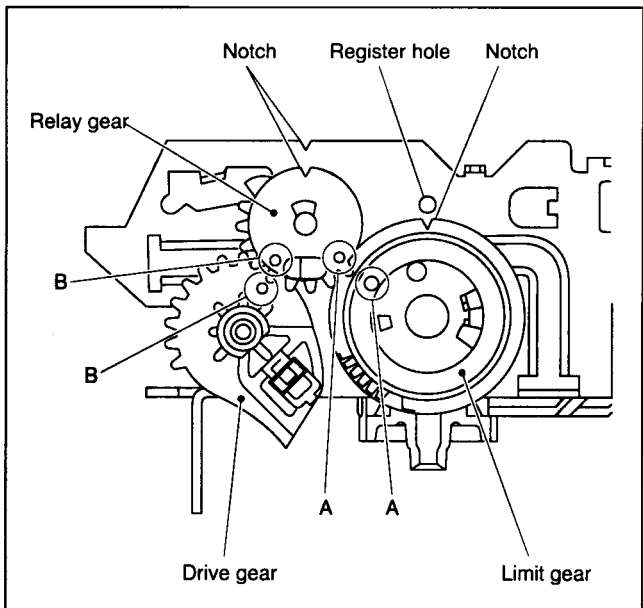


Fig. 2-3-7

2.4 COMPATIBILITY ADJUSTMENT

Notes:

- Although compatibility adjustment is very important, it is not necessary to perform this as part of the normal servicing work. It will be required when you have replaced the audio control head, drum assembly or any part of the tape transport system.

- To avoid any damage to the alignment tape while performing the compatibility adjustment, get a separate cassette tape (for recording and play back) ready to be used for checking the initial tape running behavior.

2.4.1 Checking/Adjustment of FM Waveform Linearity

- Connect the oscilloscope to TP106(PB FM/COL) of the main board assembly and to TP111(D.FF) of the main board assembly for external sync connection.
- Playing the alignment tape SP, observe the FM waveform.
- Press the channel buttons (▲) and (▼) buttons simultaneously during playback to enter the manual tracking mode (This also brings tracking to the center.)
- Make sure that there is no significant level drop of the FM waveform caused by the tracking operation, with its generally parallel and linear variation ensured. Perform the following adjustments when required. (Fig.2-4-1)
- Slightly loosen the set screw under the pole base assembly with a 1.25 mm hexagonal wrench (Take care not to loosen too much). (Fig.2-4-2)
- Reduce the FM waveform while pressing the channel buttons (▲, ▼) during playback. If a drop in level is found on the left side as shown in Fig.2-4-3, turn the guide roller of the pole base assembly (supply side) with the roller driver to make the FM waveform linear. If a drop in level is on the right side, likewise turn the guide roller of the pole base assembly (take-up side) with the guide roller to make it linear. (Fig.2-4-3)
- Then playtape (EP) and make sure that the FM waveform varies in parallel and linearly with the tracking operation. When required, perform fine-adjustment of the guide roller of the pole base assembly (supply or take-up side).
- After adjustment, tighten the set screw under the pole base assembly. (Take care not to tighten too much)
- After tightening the set screw, play the alignment tape (SP) and (EP) again to make sure that the FM waveform has correct variation.

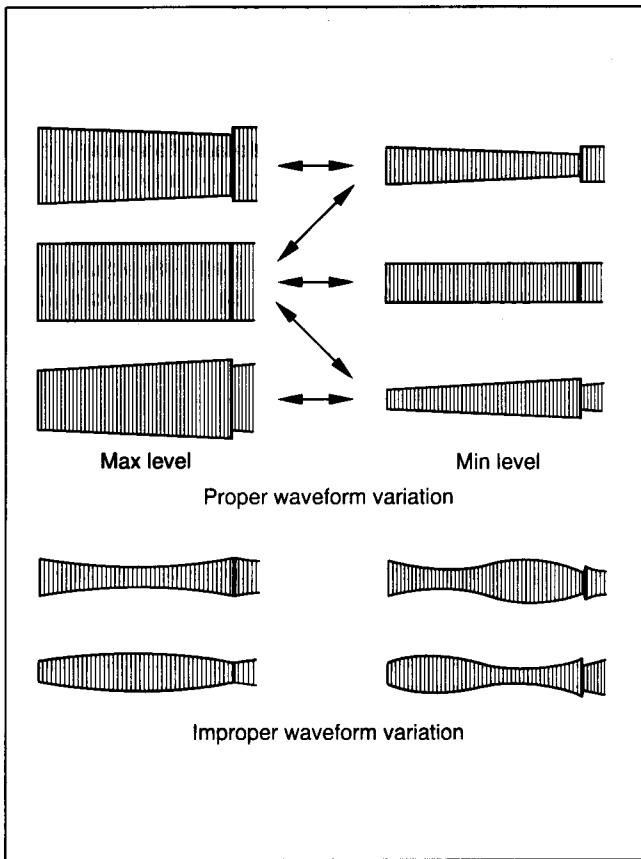


Fig. 2-4-1

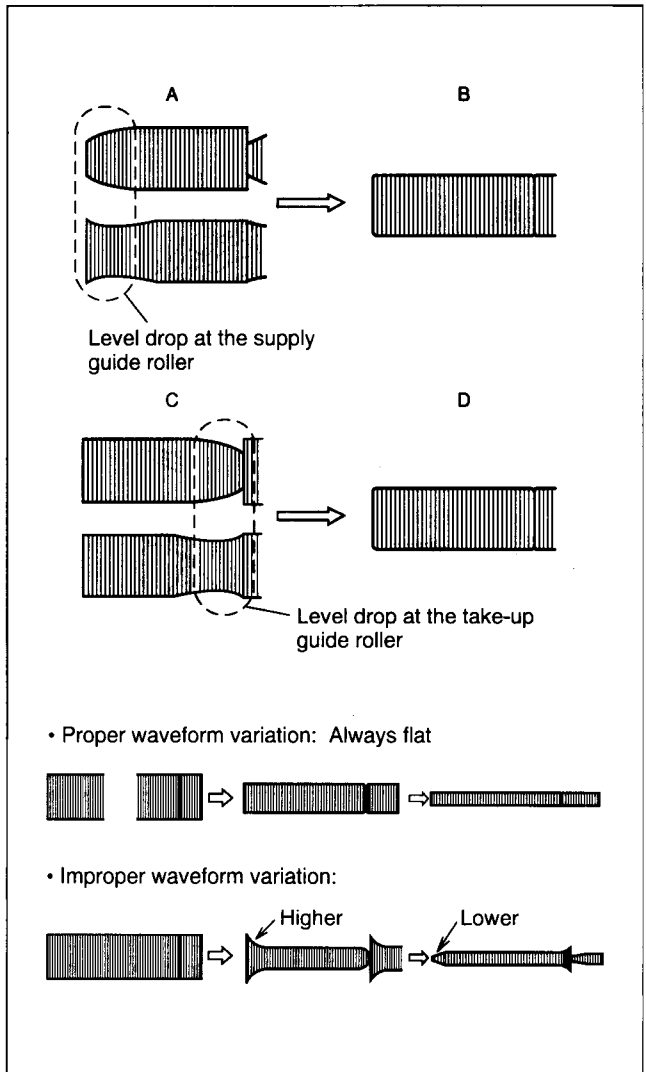


Fig. 2-4-3

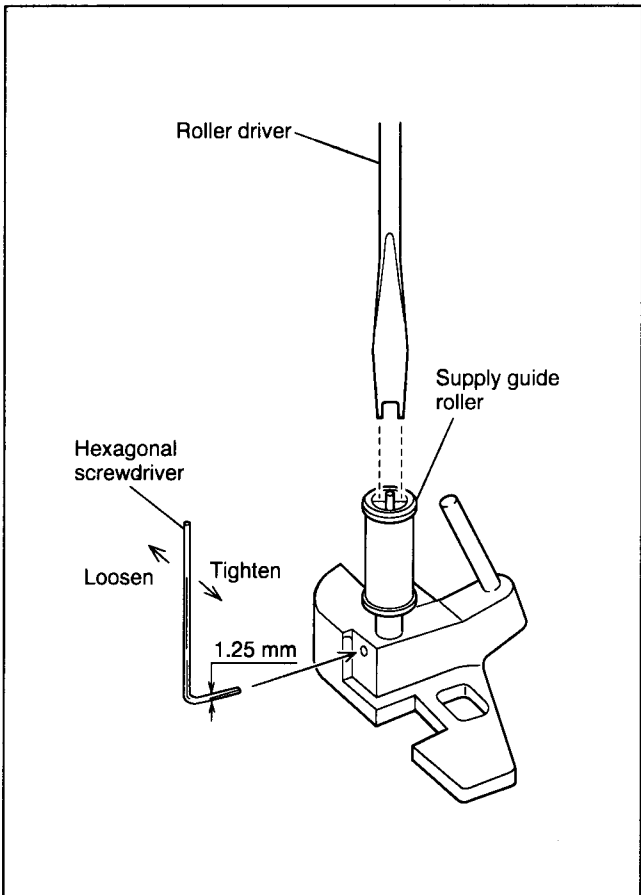


Fig. 2-4-2

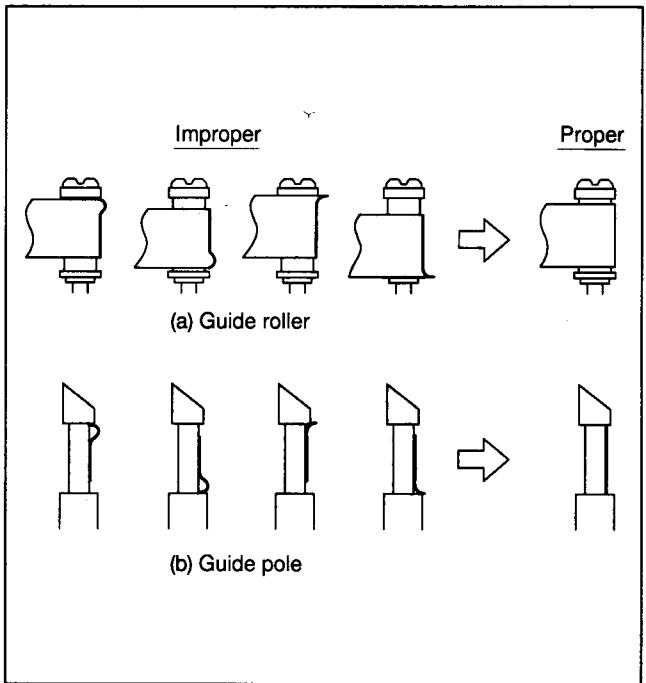


Fig. 2-4-4

2.4.2 Checking/Adjustment of the Height and Tilt of the Audio Control Head

Note: Set a temporary level of the height of the A/C head in advance to make the adjustment easier. (See Fig.2-2-14)

- (1) Connect CH-1 of the oscilloscope to AUDIO OUT and CH-2 to TP4001 (CTL P) of the main board and observe the waveforms on both channels in the ALT mode.
- (2) Play the alignment tape (SP) and adjust it by turning screws (1), (2) and (3) little by little until the waveform of both the audio output signal and the control pulse reach maximum. Screw (1) and screw (3) are for adjustment of tilt and screw (2) for azimuth.

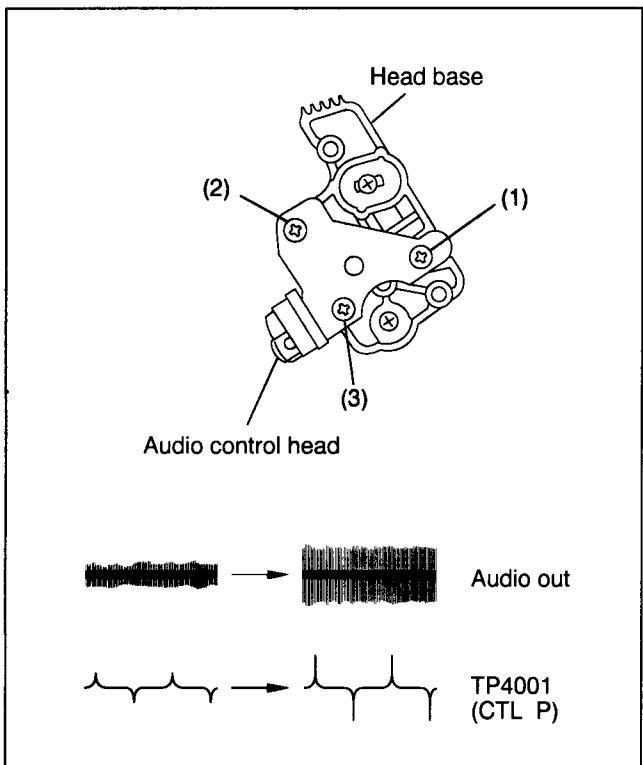


Fig. 2-4-5

2.4.3 Checking/Adjustment of the Audio Control Head Phase (X-Value)

- (1) Connect the oscilloscope to TP106(PB FM/COL) of the main board assembly and to TP111(D.FF) of the main board assembly for external sync connection.
- (2) Play the alignment tape (SP), and observe the FM waveforms.
- (3) Press the channel buttons (▲) and (▼) buttons simultaneously during playback to enter the manual tracking mode (This also brings tracking to the center.)
- (4) Loosen screws (4) and (5) so that the A/C head position bit is set as indicated in Fig.2-4-6.
- (5) Turn the A/C head position and first move the audio control head fully up to the capstan head. Then gradually return the audio control head toward the drum and stop it where the FM waveform reaches its maximum for the first time. Then tighten screw (4) temporarily.

- (6) Then play the alignment tape (EP)
- (7) Press the channel buttons (▲) and (▼) buttons simultaneously during playback to enter the manual tracking mode (This also brings the tracking to the center.)
- (8) Perform the tracking operation and make sure that the FM waveform is at its maximum.
- (9) If it is not at maximum, loosen the temporarily tightened screw (4) and turn the A/C head position bit to bring the audio control head to a position, around where the waveform reaches its maximum for the first time. Then tighten screws (4) and (5).

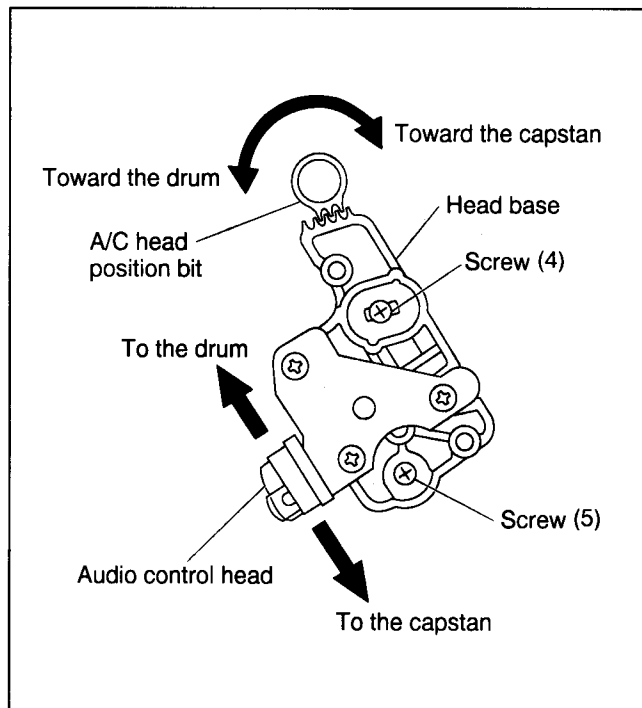


Fig. 2-4-6

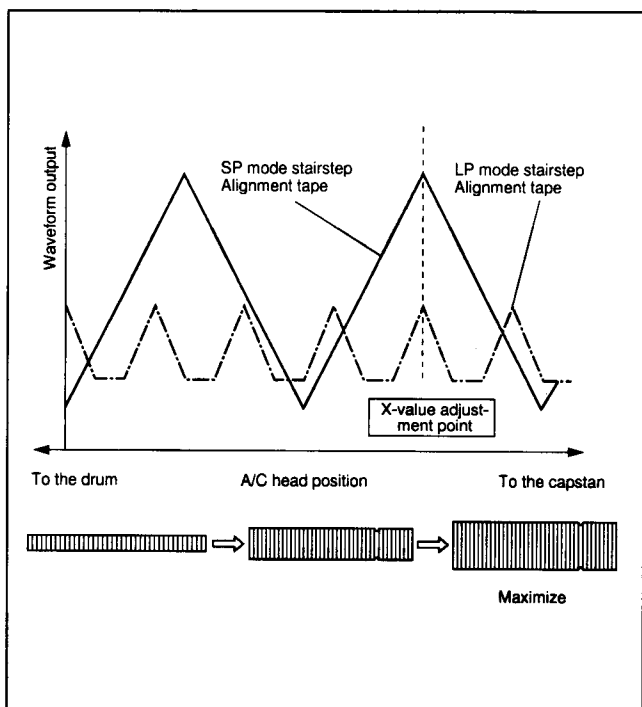


Fig. 2-4-7

Note: Adjustment is not usually necessary for the tension stud. Perform this adjustment only when it is out of position.

- (1) Connect the oscilloscope to TP106(PB FM/COL) of the main board assembly and to TP111(D.FF) of the main board assembly for external sync connection.
- (2) Playing the alignment tape (EP) and observing the FM waveform, make sure that the auto tracking operation is complete.
- (3) Press the button "D" of the presetting unit twice.
- (4) Make sure that the tape (EP) is not ejected.
- (5) If ejected, again perform the phase (X-value) adjustment of the audio control head.

2.4.5 Checking/Adjustment of the Tension Pole

- (1) Check the back tension cassette gauge to make sure that the indicator points to 29 - 46 g-cm.
- (2) If the indicated value is outside this range, carry out the following adjustment steps.
 - 1) Select the mechanism servicing mode. (See 1.5 MECHANISM SERVICE MODE)
 - 2) While in the Play mode, turn the adjustment pin with a straight-slot screwdriver. (See Fig.2-4-8).

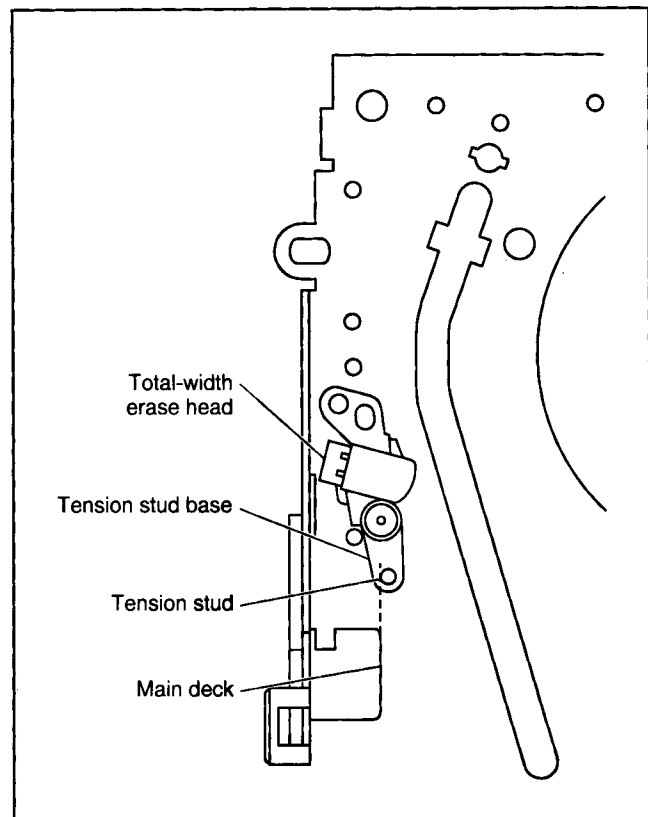
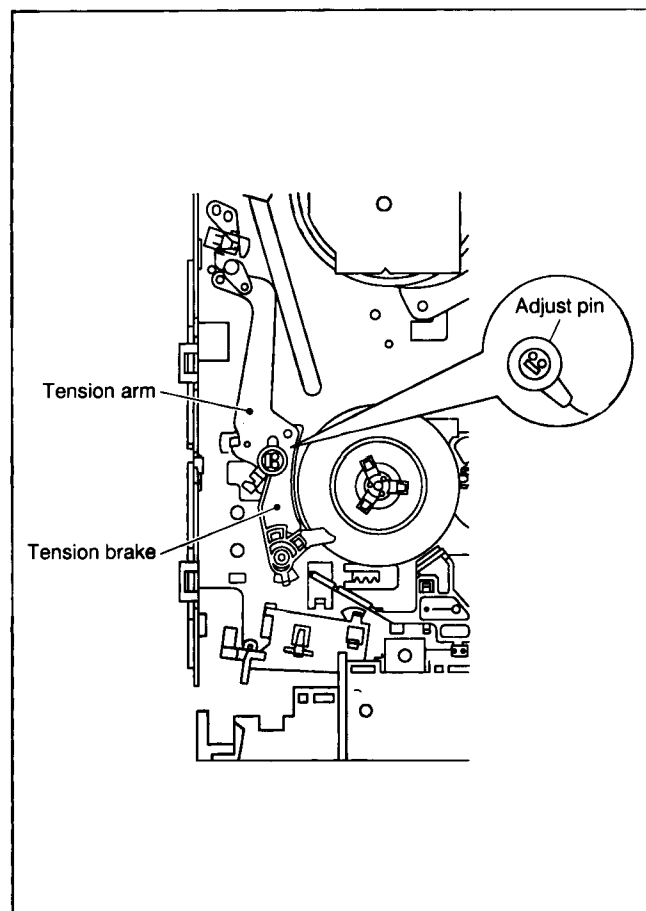
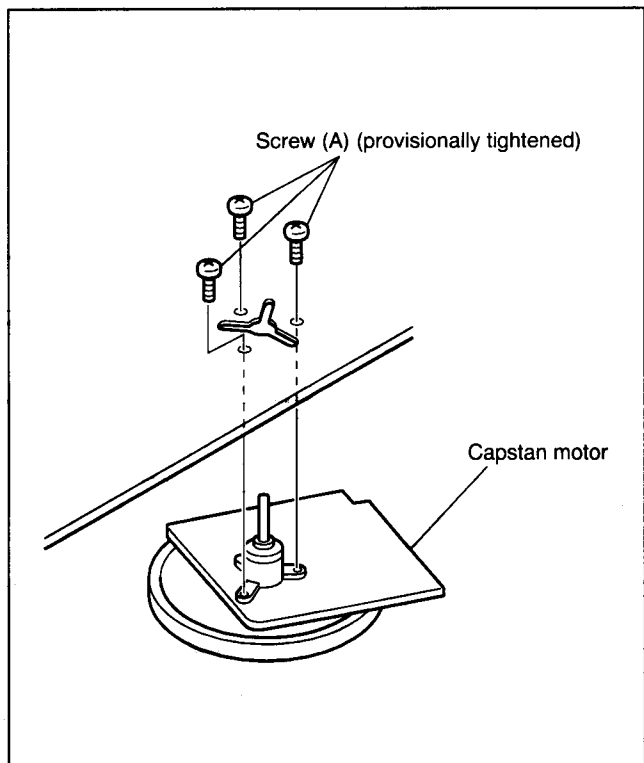


Fig. 2-4-9

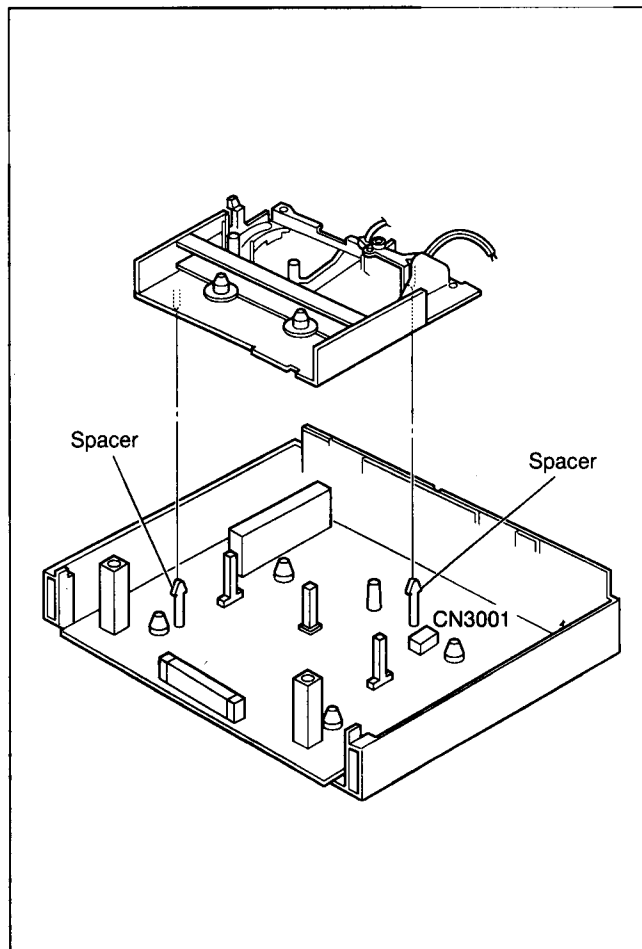
How to Mount the Capstan Motor (Centering the Mounting Position)

When the capstan motor has once been removed and then reinstalled out of the initial correct position in the rotational direction, the capstan motor current may be unstable during operation in high or low temperatures. This may result in greater Wow & Flutter and occasionally in power breakdown because of current over - load. Install the capstan motor while following the procedure given below. (The capstan motor is centrally located when the unit is shipped from the factory.)

Provisionally tighten the three screws (A) securing the capstan motor.



2. Install the mechanism to which the capstan motor is provisionally fastened on the bottom chassis which incorporates the Main board assembly. (No need to tighten the screws for mounting the mechanism)
Make sure that all the connectors for the mechanism and the Main board are correctly installed.



3. Securely tighten the three screws (A), especially making sure that the connector CN3001 of the capstan motor is correctly mounted.

Note: *When the capstan motor has been replaced with a new one, perform recording in the LP mode for at least 2 minutes at normal temperatures immediately before starting the FF/REW or SEARCH operations (Aging).*

Mechanism Timing Chart

Mechanism mode

EJECT END CASS-UP

CASS-INS

FF/REW

STOP

REV

SLOW/STILL

PLAY

Control plate mark

E U

CI

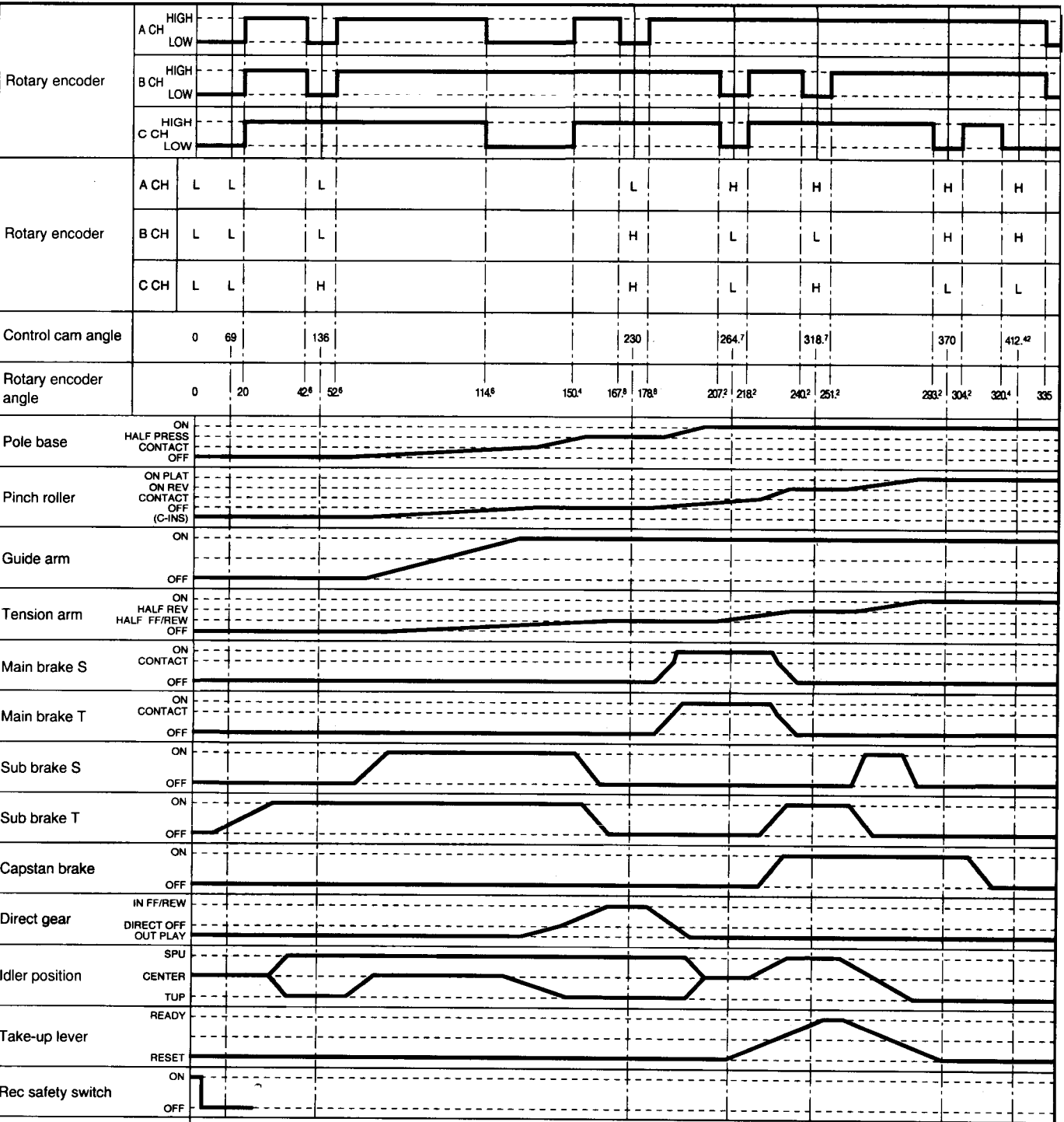
FR

ST

R

SL

P



Operation mode

Timer REC standby	Backspace	Slow FOR	REC pause
STOP (drum at stop)	Search REW		REC
POWER OFF (cassette loaded)	Slow REW		Search FF
			STOP (drum in motion)

SECTION 3 ELECTRICAL ADJUSTMENT

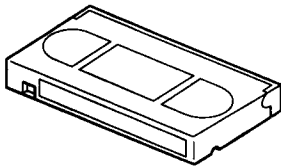
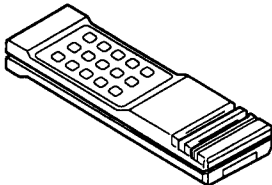
3.1 PRECAUTION

Electrical adjustment are required after replacing circuit components and certain mechanical parts. It is important to perform these adjustments only after all repairs and replacements have been completed. Also do not attempt these adjustments unless the proper equipments is available.

3.1.1 Required test equipment

- ① Colour television or monitor
- ② Oscilloscope: wide-band,dual-trace,triggered delayed sweep
- ③ Frequency counter
- ④ Digital voltmeter
- ⑤ Signal generator: RF/IF sweep/maker
- ⑥ Signal generator: PAL/SECAM colour bar, stairstep
- ⑦ Recording tape
- ⑧ Numeric-key remote controller(provided)

3.1.2 Required adjustment tools

Alignment tape (SP,stairstep) 4822 397 30262	Presetting unit 4822 395 90915
	

3.1.3 Colour bar signal,colour bar pattern

- PAL colour bar signal

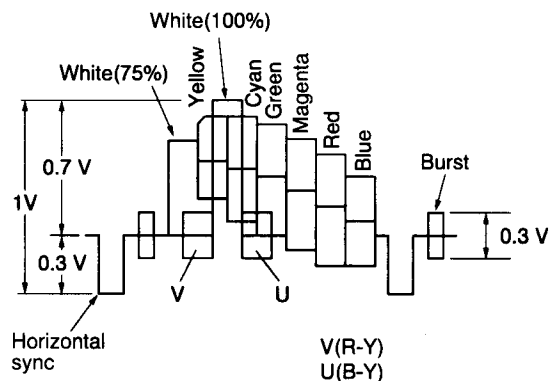


Fig.3-1-1 PAL colour bar signal waveform

- PAL colour bar pattern

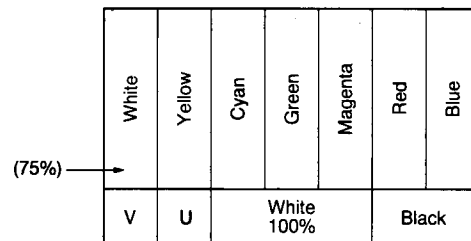


Fig.3-1-2 PAL colour bar pattern

Note:

Be sure to remove R3238 (MAIN PWB ASS'Y) when replacing the system controller IC (MAIN PWB ASS'Y IC3001) and the EEPROM (MAIN PWB ASS'Y IC3004).

3.2 SERVO CIRCUIT

Notes: • Unless otherwise specified, all measurement point and adjustment parts are located on the MAIN BOARD.

• Depress button "A" on presetting unit to VCR to "code receive" mode.

3.2.1 PB switching point

Signal	• Alignment tape SP, Stairstep
Mode	• PB
Equipment	• Oscilloscope
Measurement point	• VIDEO OUT TERMINAL
Trigger slope (-)	• TP111(DRUM FF)
Adjustment tool	• Presetting unit
Specification	• $6.5 \pm 0.5H$

- (1) Connect an oscilloscope to VIDEO OUT TERMINAL and external trigger from TP111 (negative slope).
- (2) Playback the stairstep signal of the alignment tape.
- (3) Press the "O" button of the presetting unit.
- (4) The adjustment is performed automatically.

Once the adjustment is performed, the VCR will go into the STOP mode.

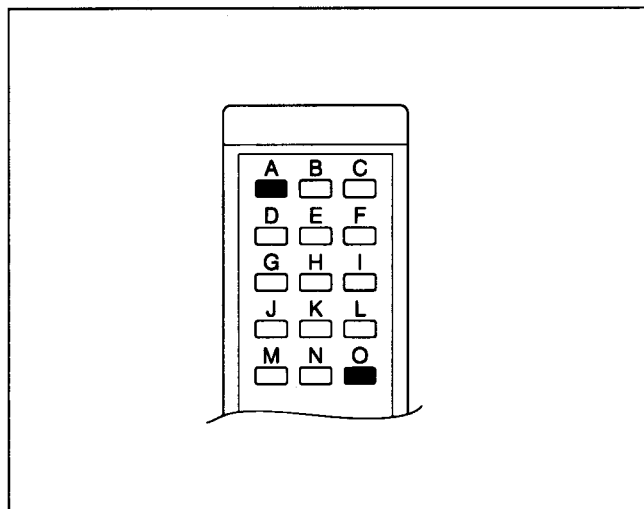


Fig.3-2-1 Presetting unit

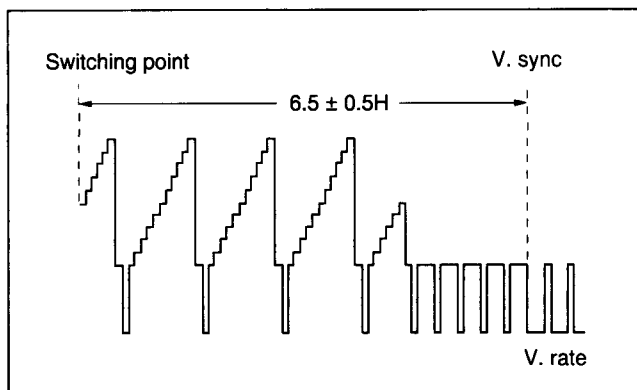


Fig.3-2-2 PB switching point

3.2.2 Slow tracking preset

Signal	• Colour bar (PAL, NTSC)
Mode	• SP/LP: PAL REC → PB(SLOW) • SP/EP: NTSC
Equipment	• TV-Monitor
Adjustment tool	• Presetting unit
Specification	• Minimum noise

Notes: • Depress button "A" on presetting unit to VCR to "code receive" mode.

• Use only buttons "B" and "C", depressing other buttons during adjustment may cause adjustment errors.

- (1) Record a PAL colour bar signal in the SP mode.
- (2) Playback recorded signal on the FWD slow mode.
- (3) Observe the display on the TV monitor and adjust for optimum noise condition (best tracking) by depressing "B" or "C" buttons of the presetting unit.
- (4) Depress the STOP button.
- (5) Confirm that the bar noise is not visible on the TV monitor in the slow mode.
- (6) Repeat steps (2) to (5) in the LP mode.
- (7) Repeat steps (1) to (6) in the NTSC mode.

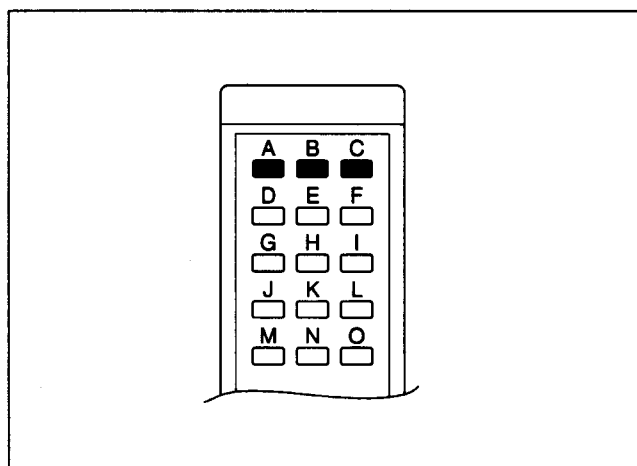


Fig.3-2-3 Presetting unit

3.3 VIDEO CIRCUIT

Notes: • Unless otherwise specified, all measurement point and adjustment parts are located on the MAIN BOARD.

- Depress button "A" on presetting unit to VCR to "code receive" mode.

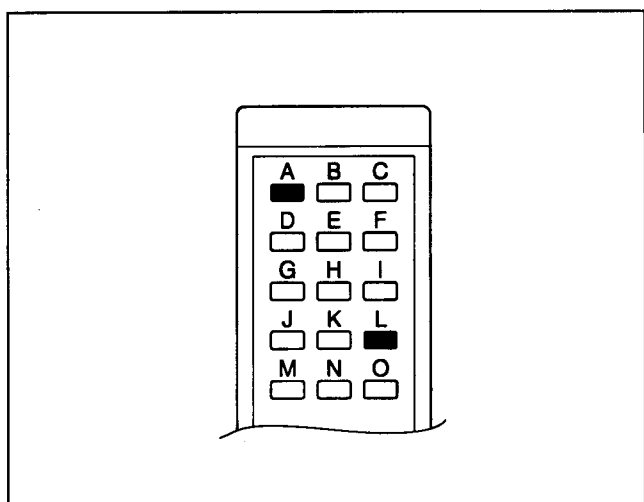


Fig.3-3-1 Presetting unit

3.3.1 Auto picture

Signal	• Monoscope
Mode	• REC then PB • SP/LP: PAL • SP/EP: NTSC • BEST: OFF
Adjustment tool	• Presetting unit
Specification	• STOP mode

- (1) Set B.E.S.T feature to OFF on MENU screen.
- (2) Record a monoscope signal in the SP mode.
- (3) Playback the recorded signal.
- (4) Press the "L" button of the presetting unit during playback
- (5) Confirm that VCR will go into the STOP mode.
- (6) Repeat steps (3) to (5) in the LP mode.
- (7) Repeat steps (2) to (6) in the NTSC mode.

3.4 SYSCON CIRCUIT

Notes: • Unless otherwise specified, all measurement point and adjustment parts are located on the MAIN BOARD.

- When perform this adjustment, remove the MECHANISM assembly.

3.4.1 Timer clock

Signal	• No signal
Mode	• EE
Equipment	• Frequency counter
Measurement point	• IC3301 73PIN
Adjustment part	• C3018 (TIMER CLOCK)
Specification	• 8192.057 – 8192.074 Hz 9122.0692 – 122.0695 μsec

- (1) Connect the frequency Counter to Pin No.73 of the IC3301 and GND.
- (2) Connect Pin No.71 of the IC3001 to GND.
- (3) Short-circuit both ends of the C3015 once to reset the IC3001.
- (4) Disconnect Pin No. 71, which was connected to GND at Step (2).
- (5) Adjust the C3018 trimmer capacitor so that the output from Pin No.73 of thr IC3001 falls within 8192.057 to 8192.074 Hz (122.0692 to 122.0695 μsec) range.

3.5 ON SCREEN CIRCUIT

Notes: • Unless otherwise specified, all measurement point and adjustment parts are located on the MAIN BOARD.

- Depress button "A" on presetting unit to VCR to "code receive" mode.

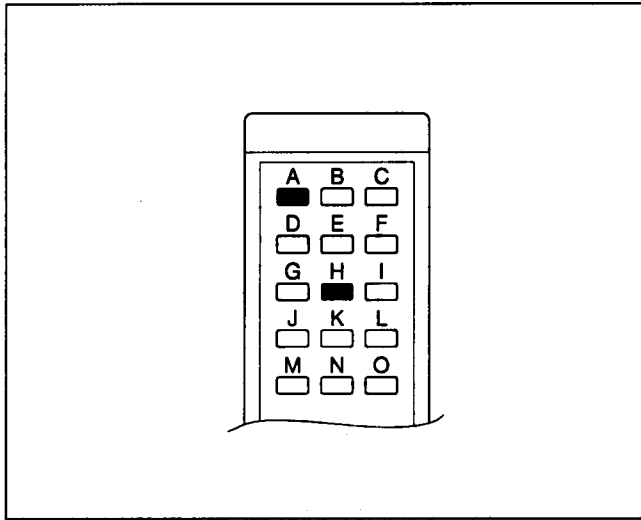


Fig.3-5-1 Presetting unit

3.5.1 Character position

Signal	• No signal
Mode	• EE
Equipment	• TV-monitor
Adjustment tool	• Presetting unit
Specification	• Character centre

- (1) Press the MENU button and display the on screen character.
- (2) Press "H" button on the presetting unit.
- (3) Adjust CH "+" or "-" button so that the character is centre position.
- (4) Press the OK button on remote controller to change the indications of "0E" and "0F" on the FDP.
- (5) Press "H" button on the presetting unit again to return to normal mode.

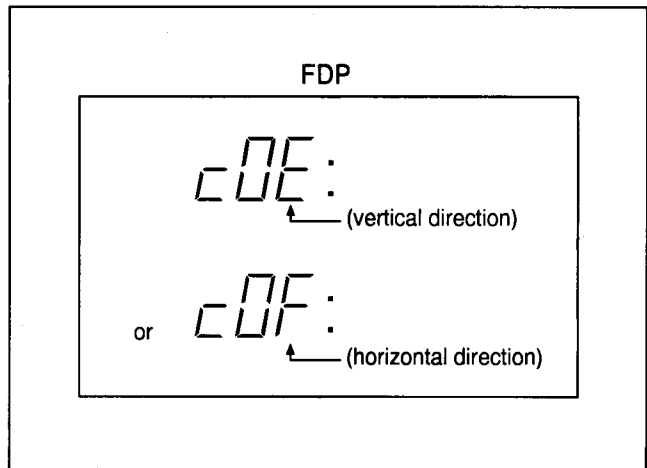



Fig.3-5-2 FDP

SECTION 4 CHARTS AND DIAGRAMS

NOTES OF SCHEMATIC DIAGRAM

Safety precautions

The Components identified by the symbol  are critical for safety. For continued safety, replace safety critical components only with manufacturer's recommended parts.

1. Units of components on the schematic diagram

Unless otherwise specified.

- 1) All resistance values are in ohm, 1/6 W, 1/8 W (refer to parts list).
Chip resistors are 1/16 W.
K: K Ω (1000 Ω), M: M Ω (1000K Ω)
- 2) All capacitance values are in μ F, (P: PF).
- 3) All inductance values are in μ H, (m: mH).
- 4) All diodes are 1SS133, MA165 or IN4148M (refer to parts list).

2. Indications of control voltage

AUX : Active at high

AUX or AUX(L) : Active at low

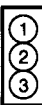
3. Interpreting Connector indications



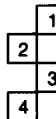
Removable connector



Wire soldered directly on board



Non-removable Board connector



Board to Board

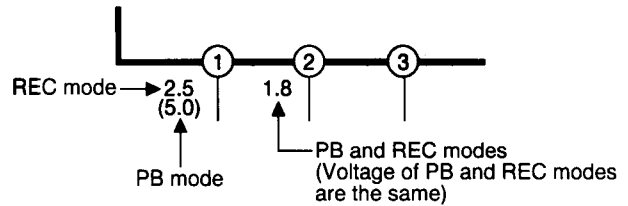


Connected pattern on board
The arrows indicate signal path

4. Voltage measurement

- 1) Video circuits
REC : Colour bar signal in SP mode, normal VHS mode
PB : Alignment tape, colour bar SP mode, normal VHS mode
— : Unmeasurable or unnecessary to measure
- 2) Audio circuits
REC : 1KHz, -8 dBs sine wave signal in SP mode, Normal VHS mode
PB : REC then playback it
- 3) Movie Camera circuits
Measured using a correctly illuminated gray scale or colour bar test charts in the E-E mode

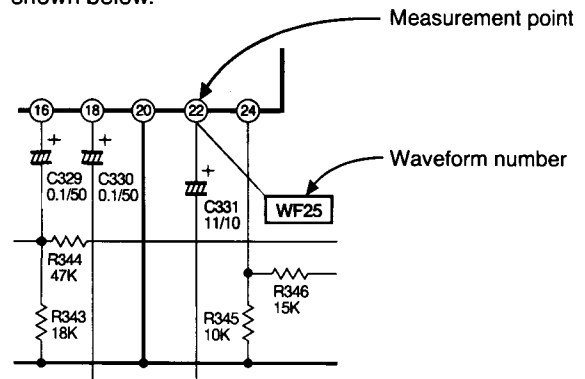
- 4) Indication on schematic diagram
Voltage Indications for REC and PB mode on the schematic diagram are as shown below.



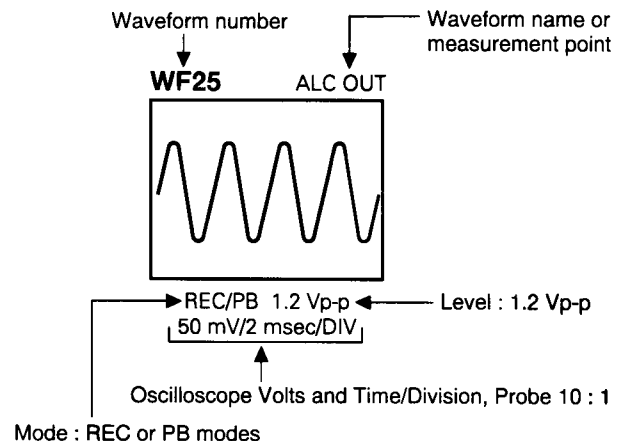
Note: If the voltages are not indicated on the schematic diagram, refer to the voltage charts.

5. Waveform measurement

- 1) Video circuits
REC : Colour bar signal in SP mode, normal VHS mode
PB : Alignment tape, colour bar SP mode, normal VHS mode
- 2) Audio circuits
REC : 1KHz, -8 dBs sine wave signal in SP mode, normal VHS mode
PB : REC then playback it
- 3) Movie Camera circuits
Measured using a correctly illuminated gray scale or colour bar test charts in the E-E mode
- 4) Indication on schematic diagram
Waveform indications on the schematic diagram are as shown below.








5) Waveform indications





6. Signal path Symbols

The arrows indicate the signal path as follows.

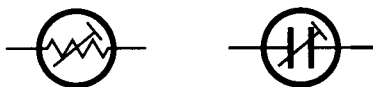
-  Playback signal path
-  Playback and recording signal path
-  Recording signal path (including E-E signal path)
-  Capstan servo path
-  Drum servo path

(Example)

-  R-Y Playback R-Y signal path
-  Y Recording Y signal path

7. Indication of the parts for adjustments

The parts for the adjustments are surrounded with the circle as shown below.



8. Indication of the parts not mounted on the circuit board

"OPEN" is indicated by the parts not mounted on the circuit board.



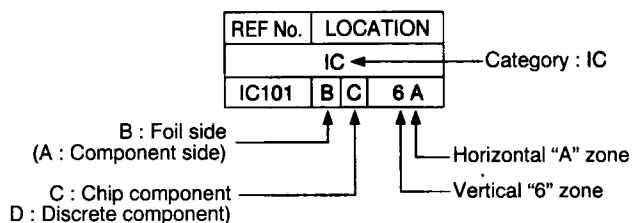
CIRCUIT BOARD NOTES

1. Foil and Component sides

- 1) Foil side (B side) :
Parts on the foil side seen from foil face (pattern face) are indicated.
- 2) Component side (A side) :
Parts on the component side seen from component face (parts face) indicated.

2. Parts location guides

Parts location are indicated by guide scale on the circuit board.



4.1 BOARD INTERCONNECTIONS

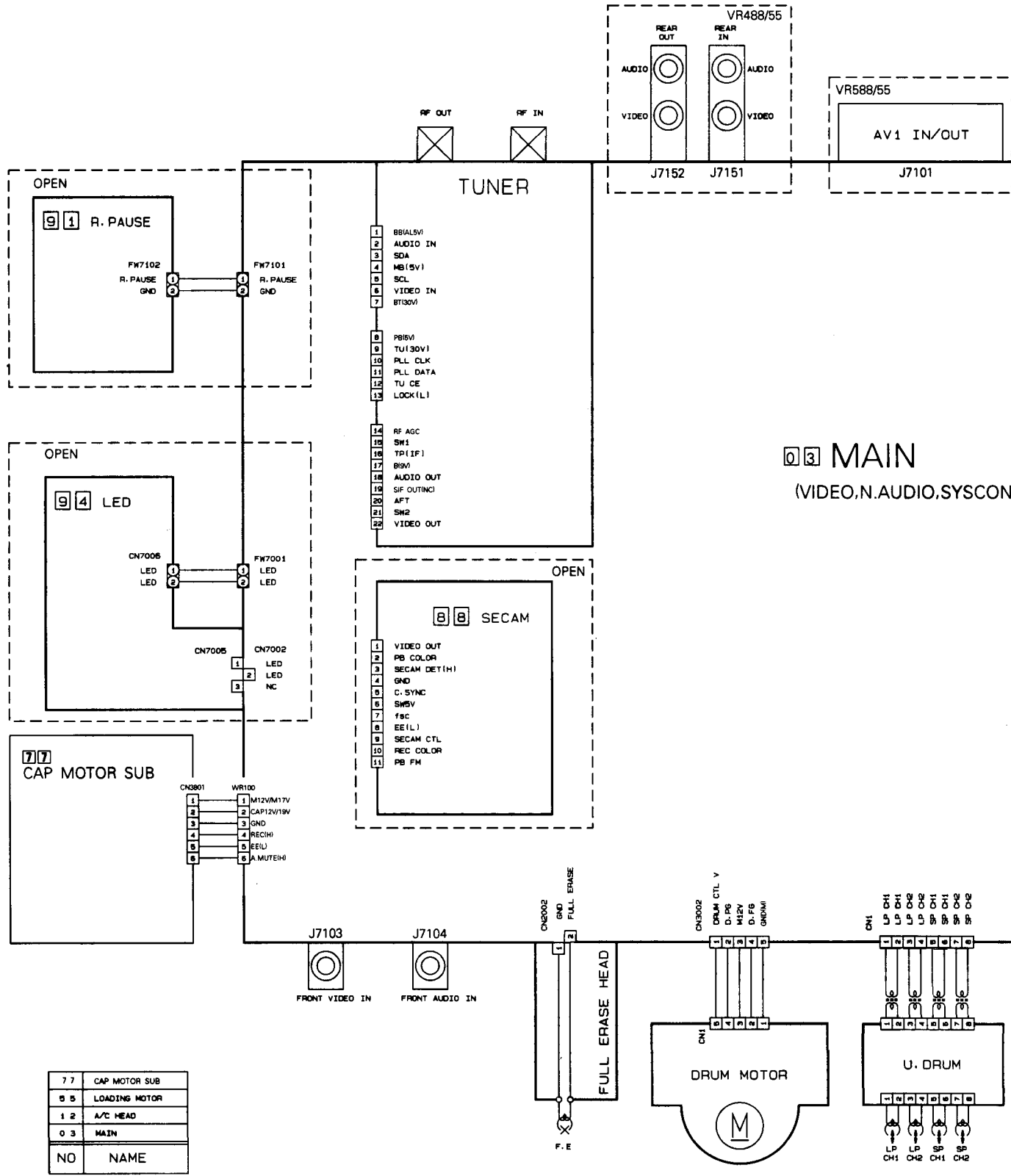
5

4

3

2

1



7 7	CAP MOTOR SUB
5 5	LOADING MOTOR
1 2	A/C HEAD
0 3	MAIN
NO	NAME

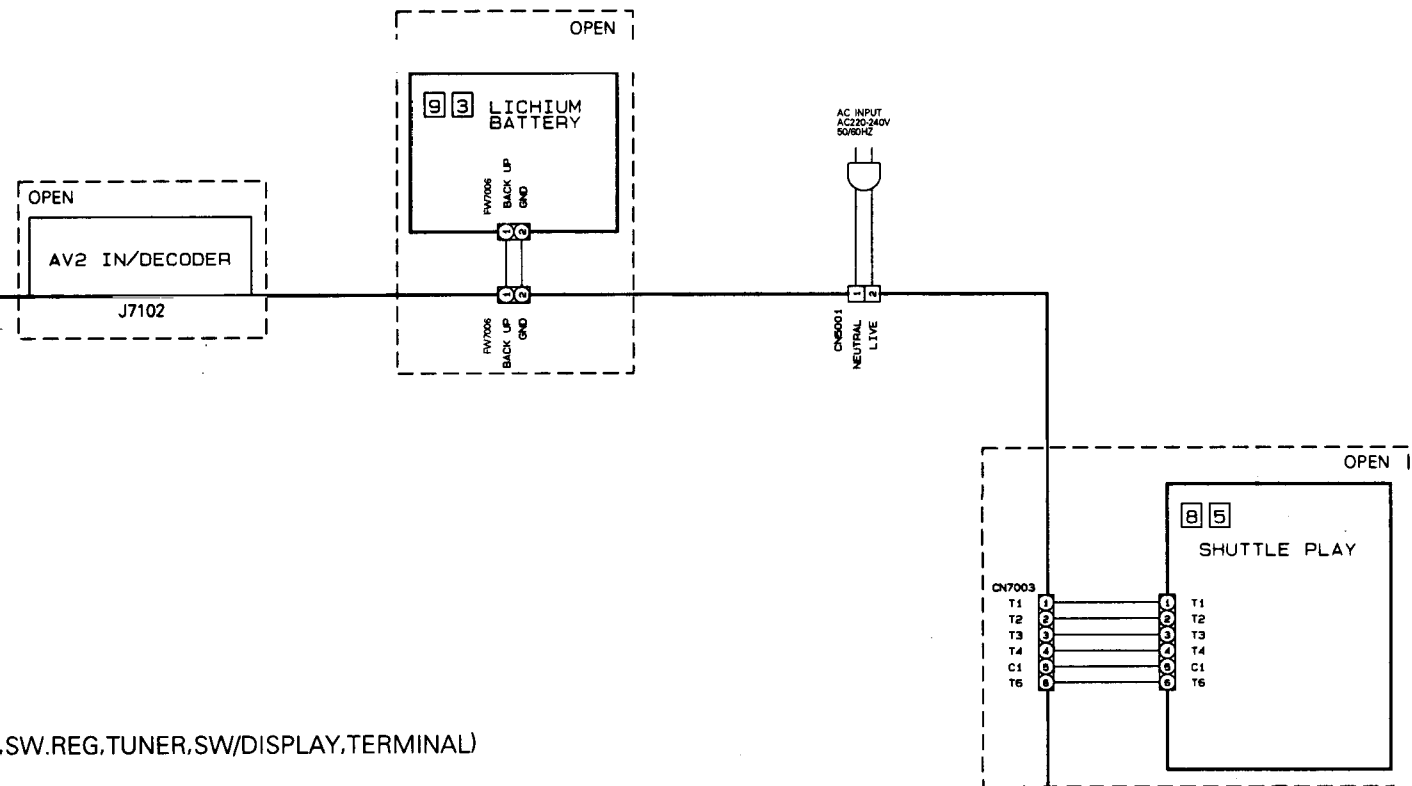
A

B

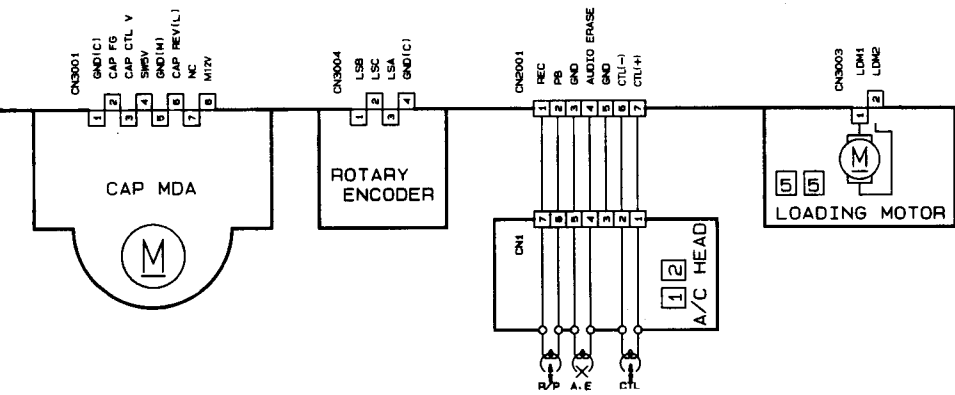
C

D

4-3



SW.REG.TUNER,SW/DISPLAY,TERMINAL)



5

4

3

2

1

OPEN

8 8 SECAM

0 3 MAIN [VIDEO/N. AUDIO]

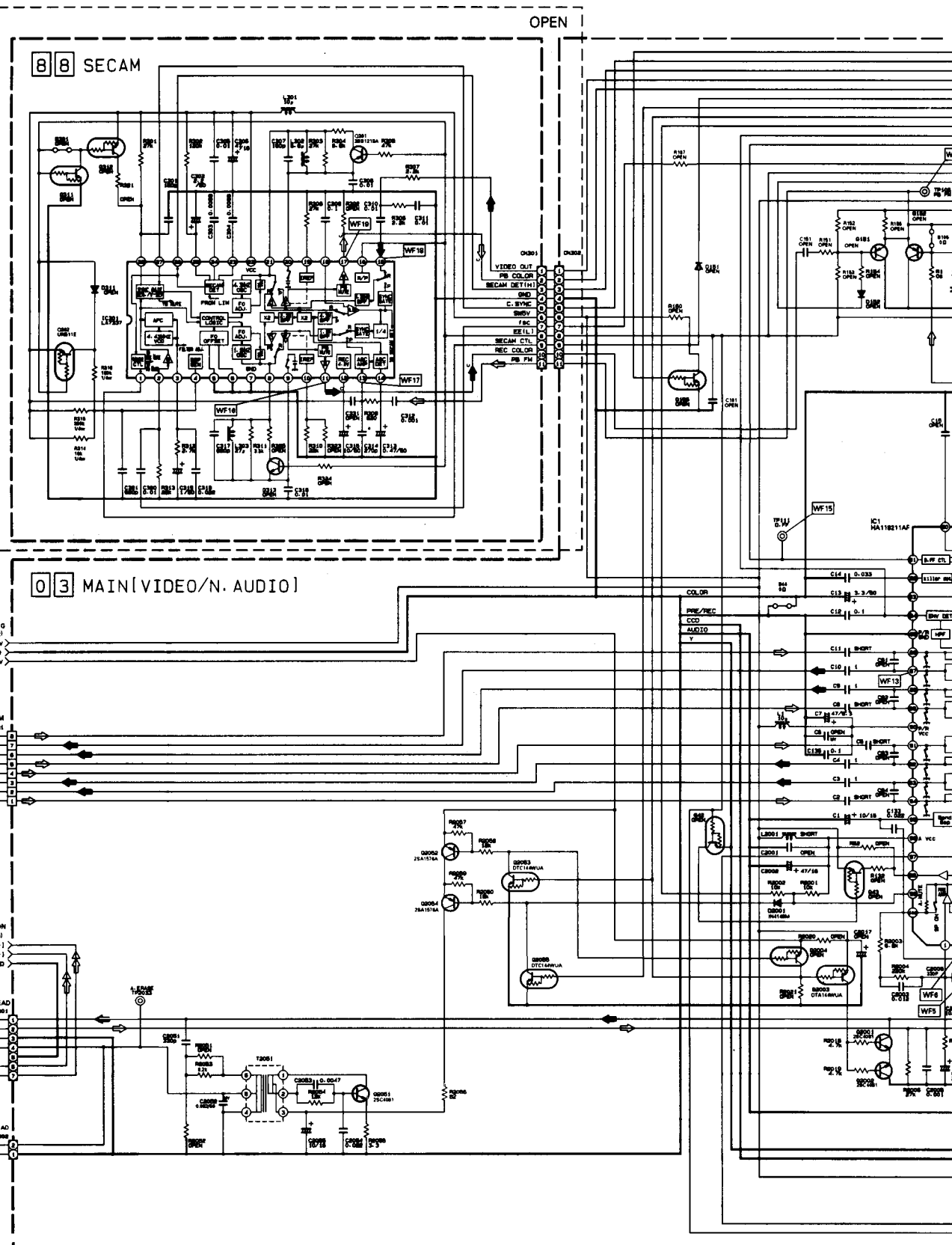
TO SW REG
(Page 4-12)
SW12
SW12

TO UDRUM
OH1
SPCH
SPCH
UPCH
UPCH

TO SYNC ON
(Page 4-10)
CTL1+
CTL1-

TO AC HEAD
C0001
P.V.R.
A.E.X.
CTL

TO FE HEAD
C0000
P.V.R.
A.E.X.



NOTES : 1. For VIDEO, PRE/REC and AUDIO waveforms, please refer to page 4-19.
2. COMPARISON CHART OF MODELS&MARK(#).

MODEL \ SYMBOL	R2009	R2013
VR488/55	1K	47K
VR588/55	0	39K

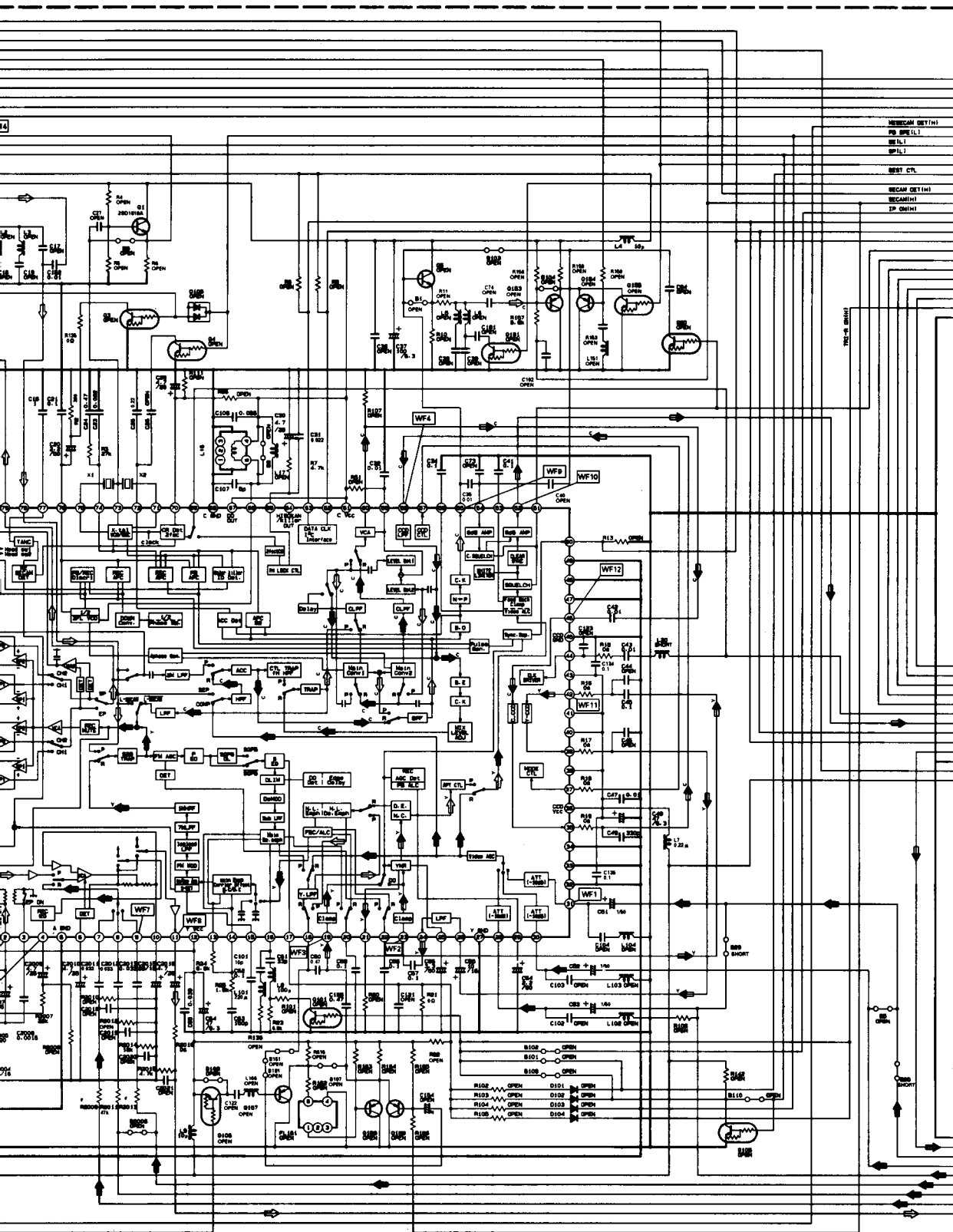
A

B

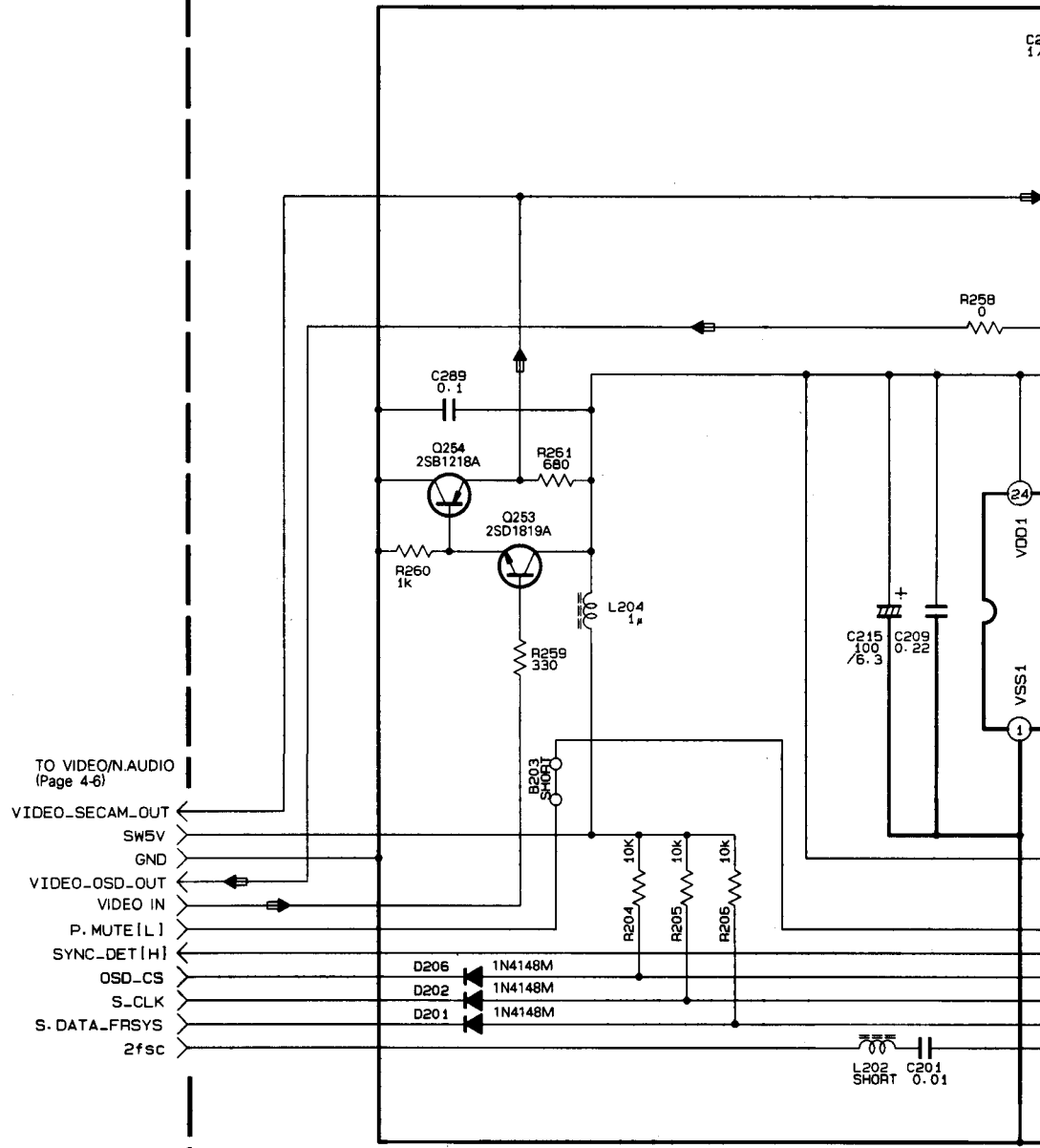
C

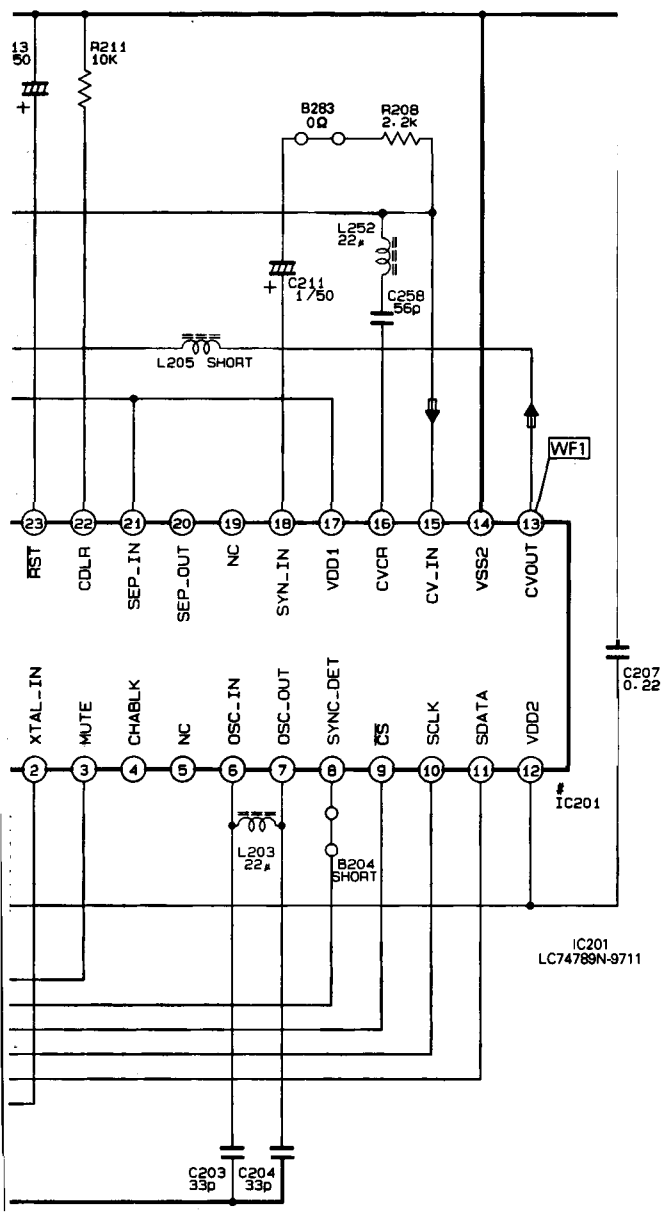
D

4-5



03 MAIN (ON SCREEN)





NOTE : For ON SCREEN waveforms, please refer to page4-19.

5

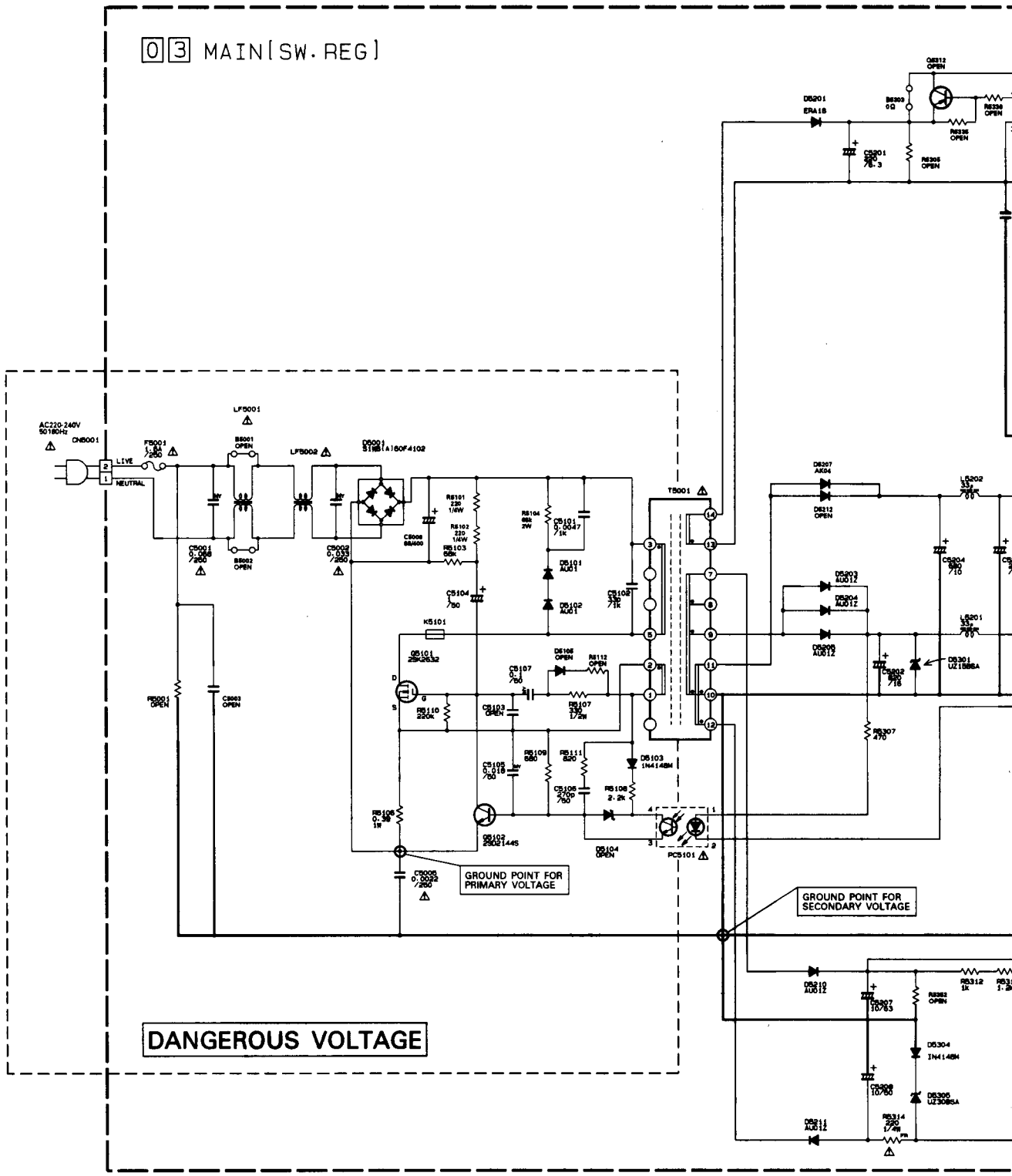
03 MAIN(SW. REG)

4

3

2

1



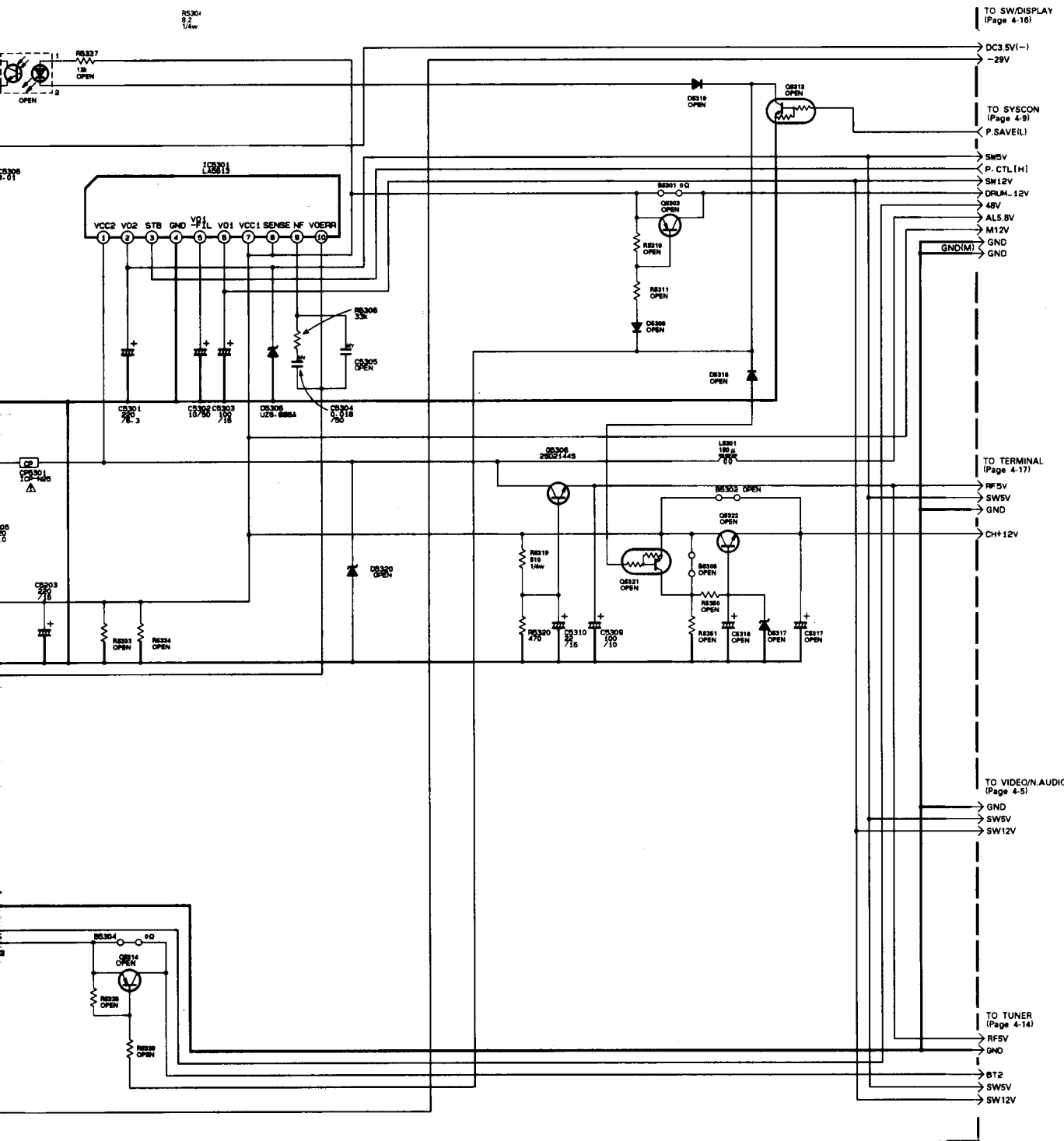
DANGEROUS VOLTAGE

A

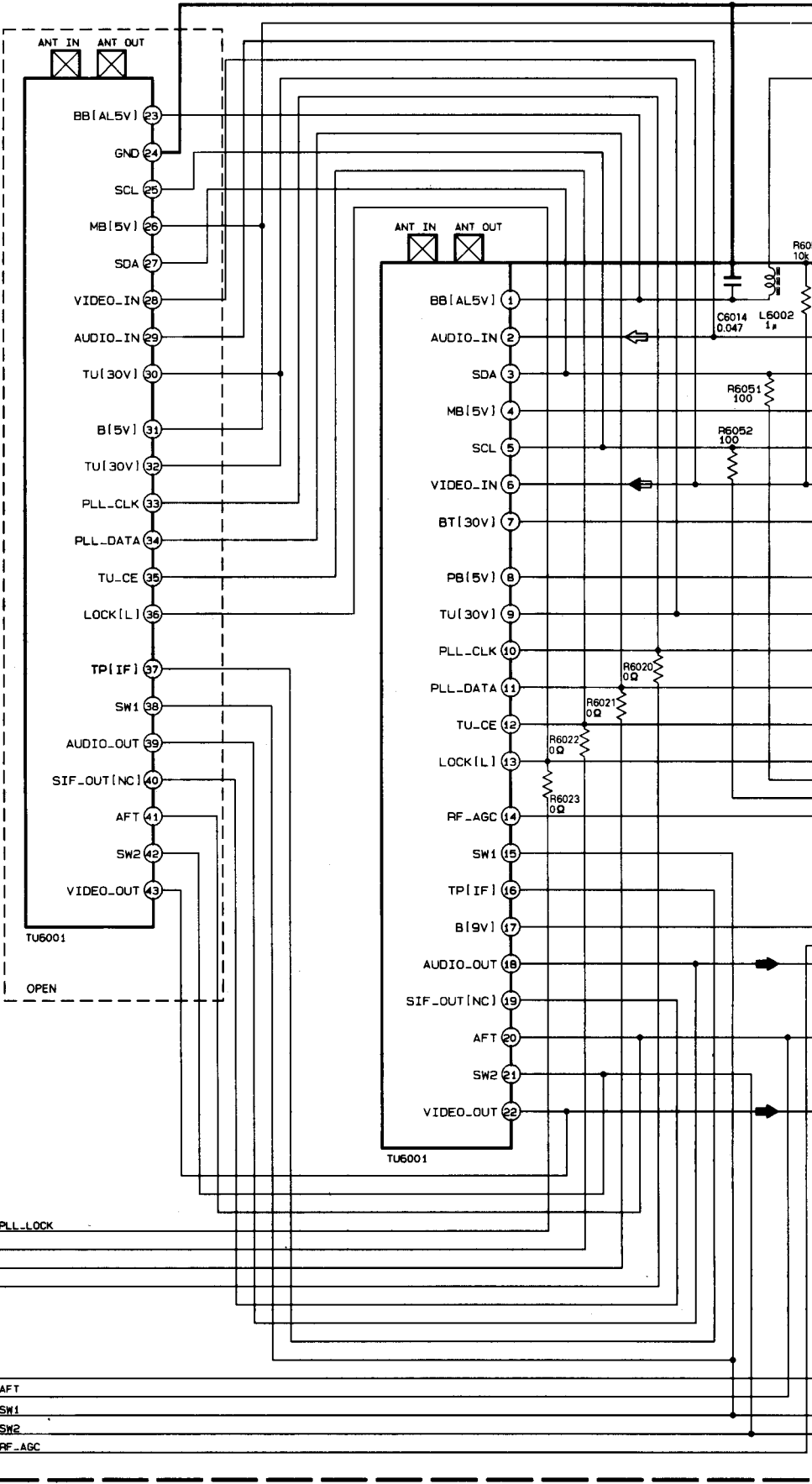
B

C

D

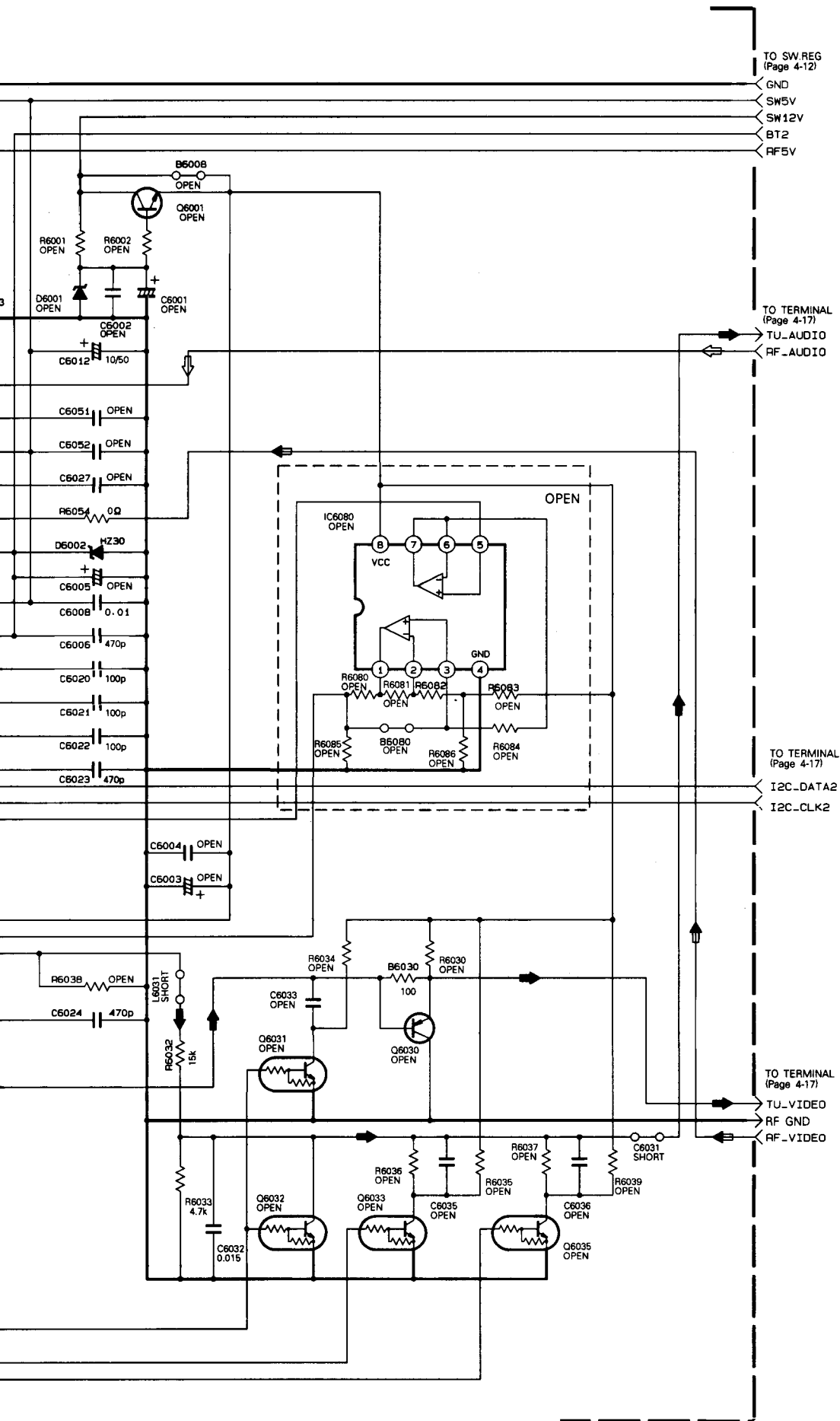


0 3 MAIN(TUNER)



TO SYSCON
(Page 4-10)
 LOCK[L] ← PLL_LOCK
 PLL_CE
 PLL_DATA
 PLL_CLK

TO SYSCON
(Page 4-10)
 TU_MUTE[H] ←
 AV/TU_CTL2 ← AFT
 AV/TU_CTL3 ← SW1
 AV/TU_CTL16 ← SW2
 AV/TU_CTL11 ← RF_AGC



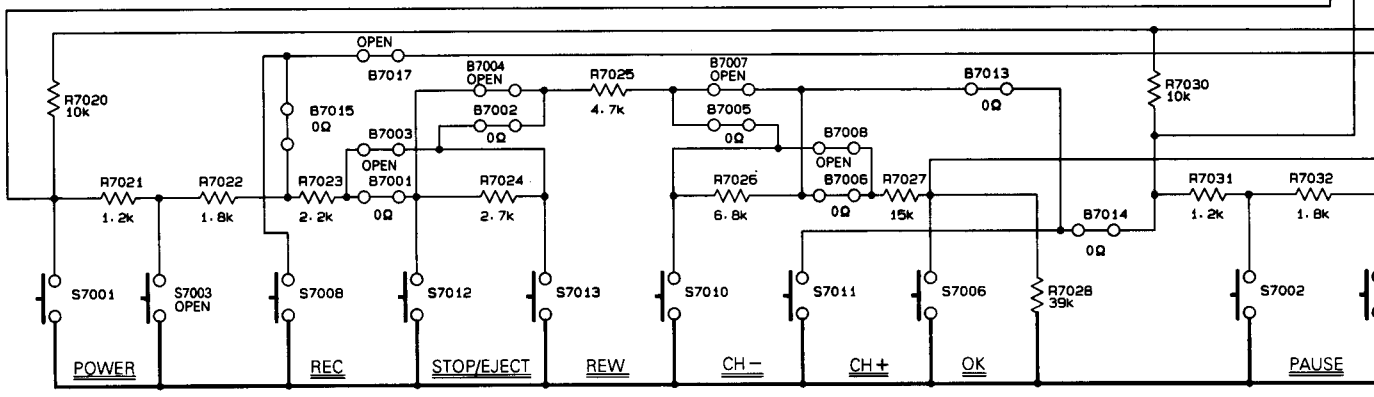
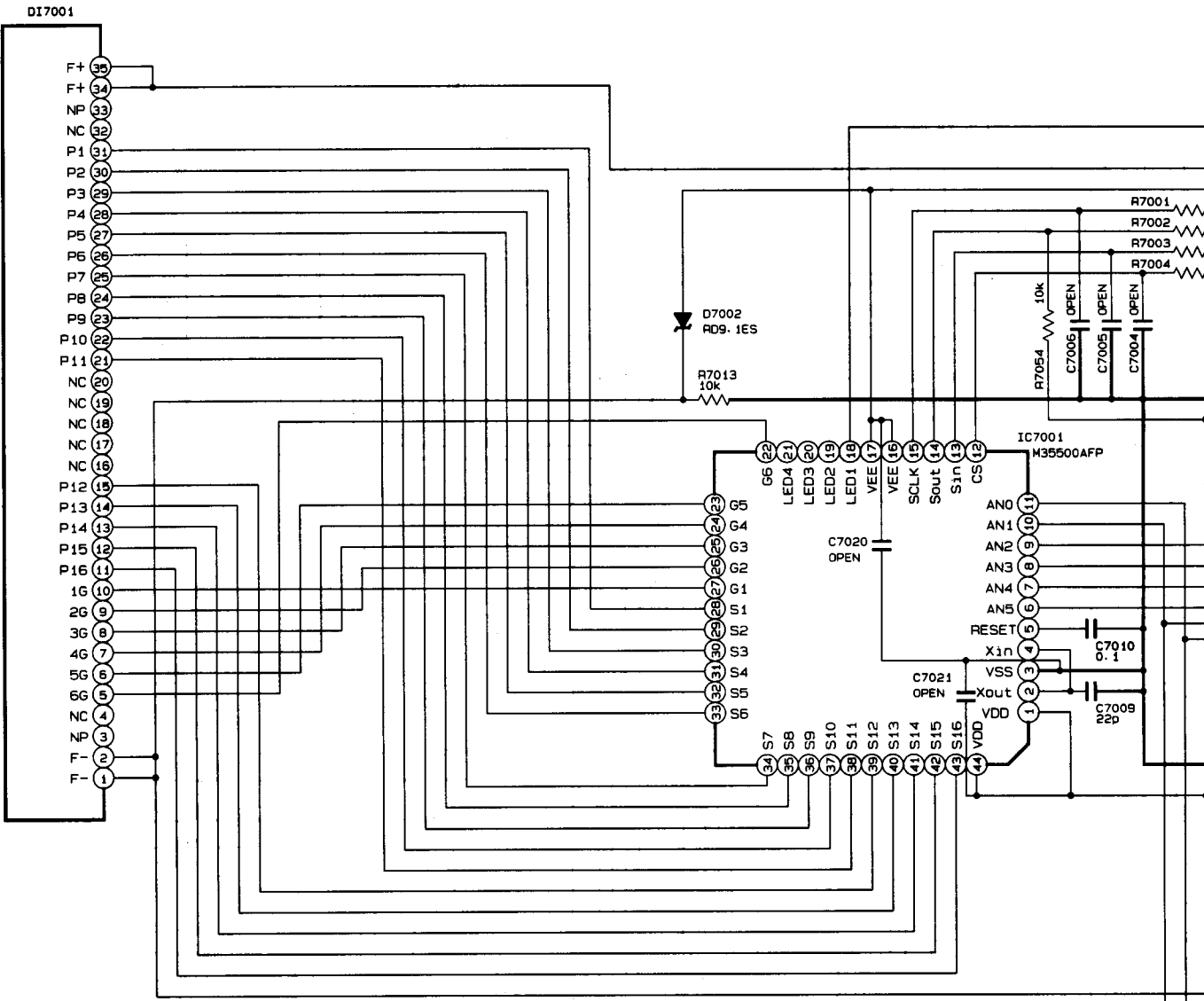
TO SW REG
(Page 4-12)
GND
SW5V
SW12V
BT2
RF5V

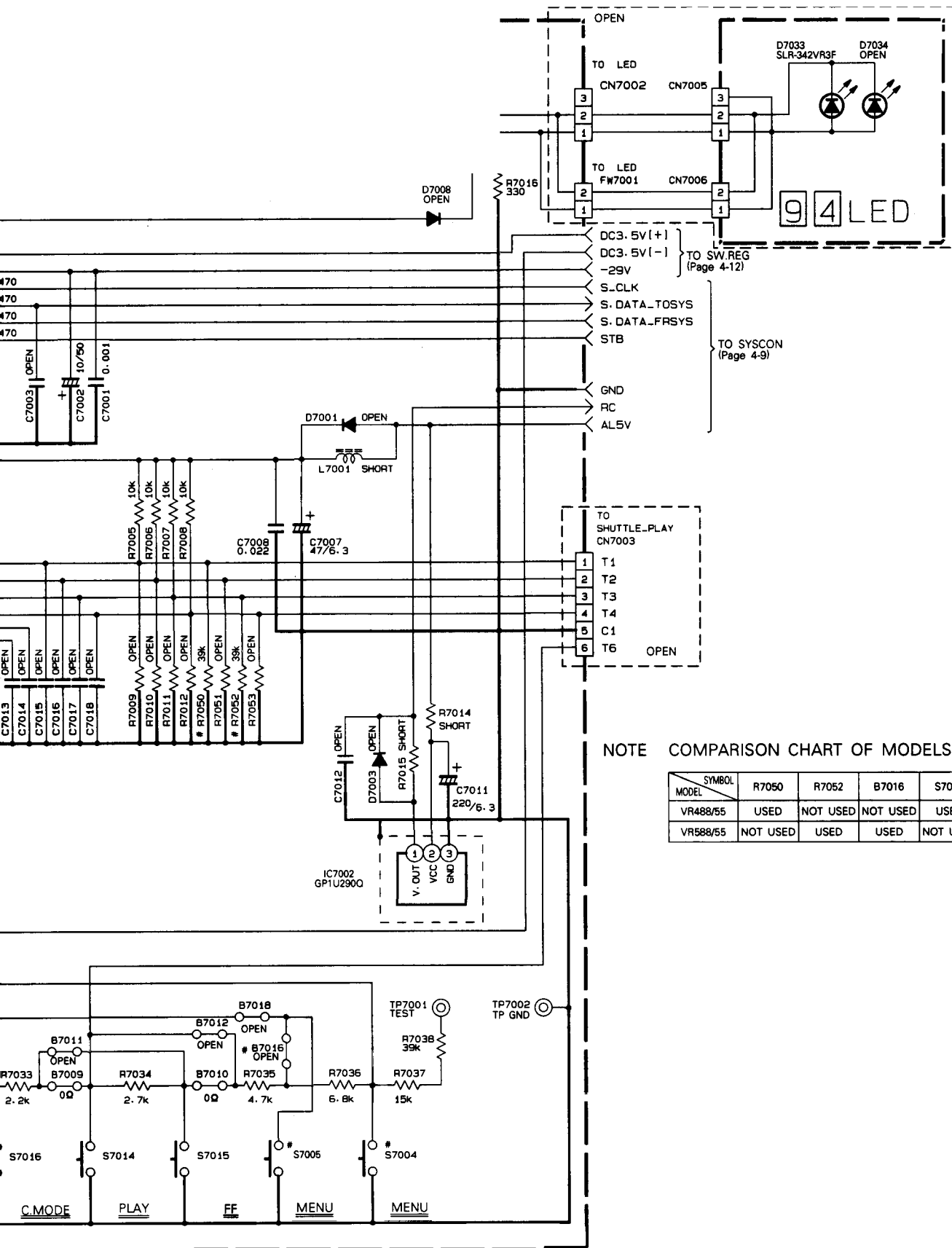
TO TERMINAL
(Page 4-17)
TU_AUDIO
RF_AUDIO

TO TERMINAL
(Page 4-17)
I2C_DATA2
I2C_CLK2

TO TERMINAL
(Page 4-17)
TU_VIDEO
RF_GND
RF_VIDEO

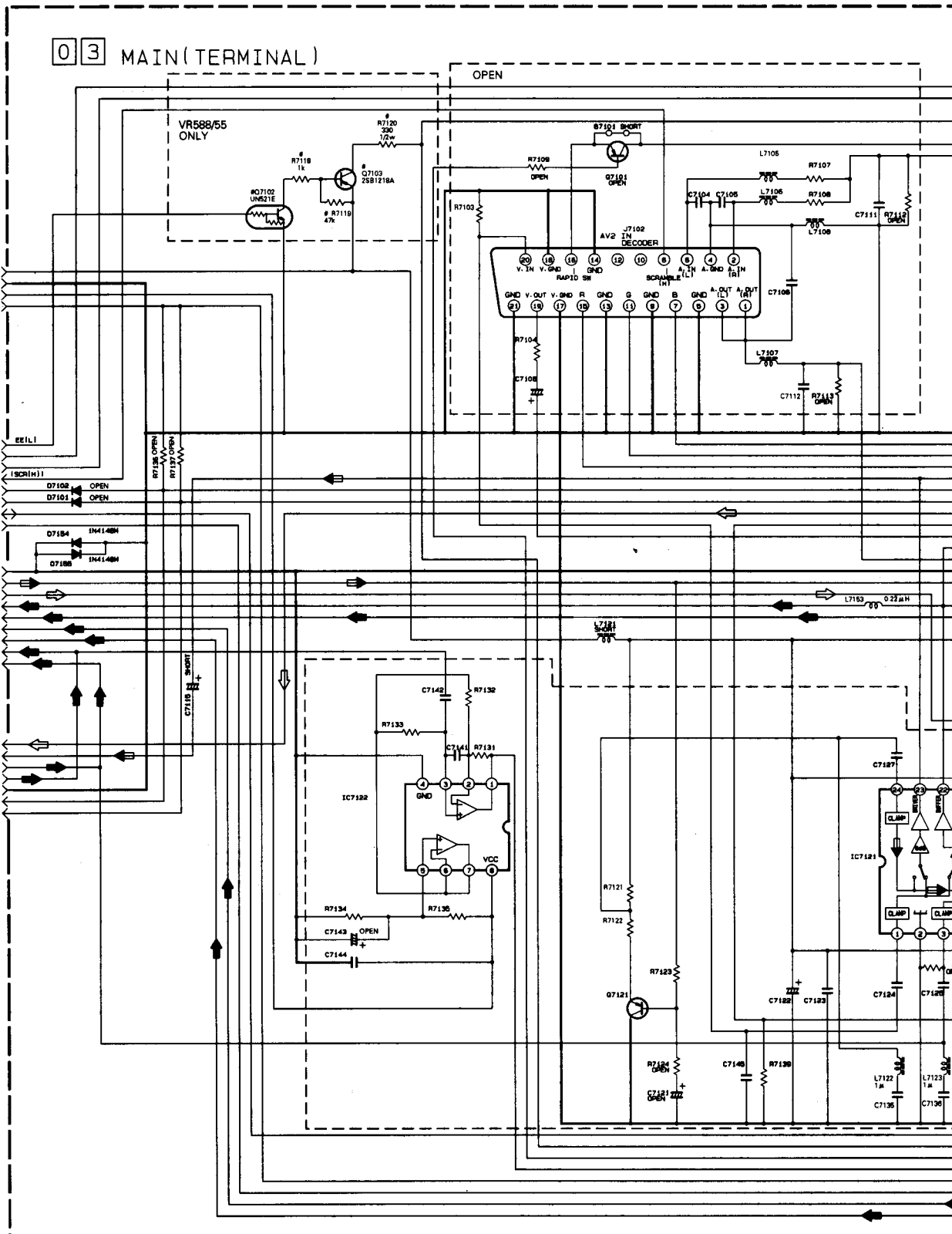
03 MAIN (SW/DISPLAY)





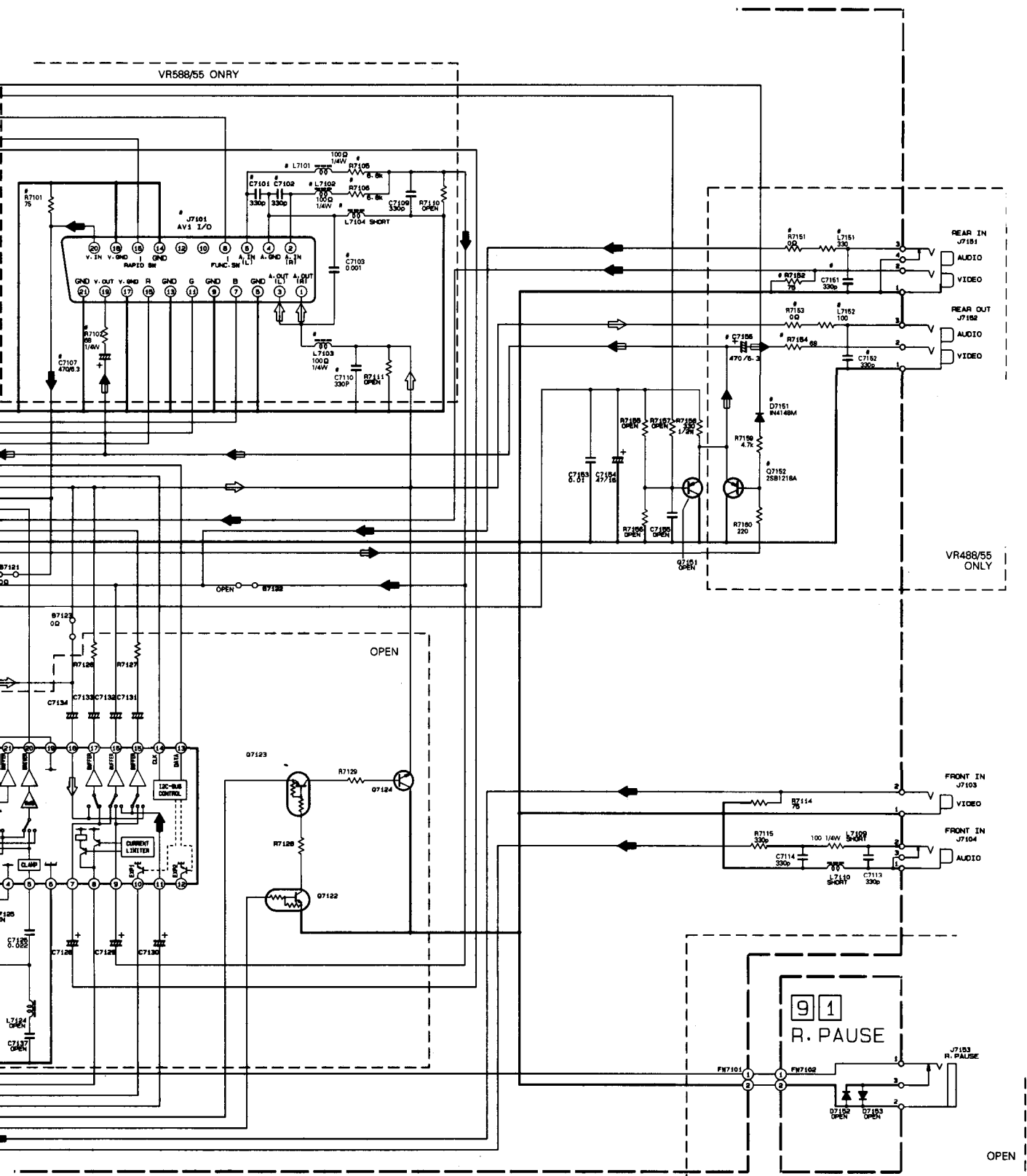
NOTE COMPARISON CHART OF MODELS&MARK(#).

SYMBOL	R7050	R7052	B7016	S7004	S7005
MODEL					
VR468/55	USED	NOT USED	NOT USED	USED	NOT USED
VR568/55	NOT USED	USED	USED	NOT USED	USED



NOTE : COMPARISION CHART OF MODEL&MARK(#).

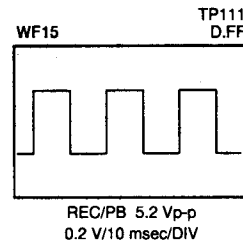
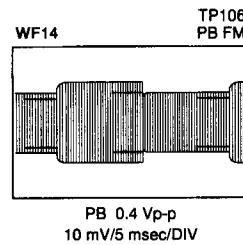
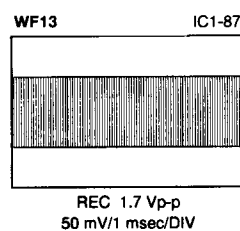
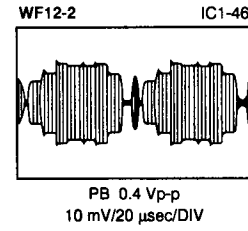
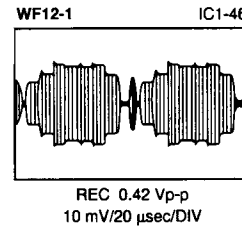
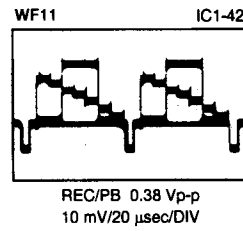
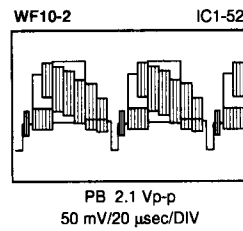
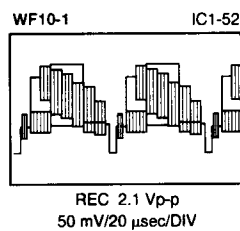
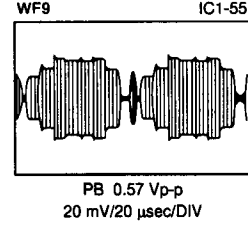
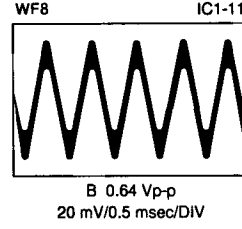
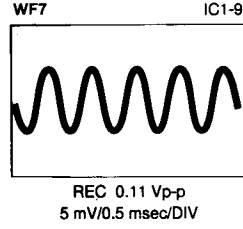
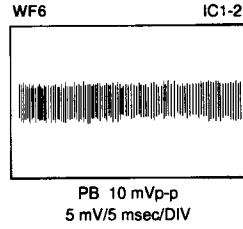
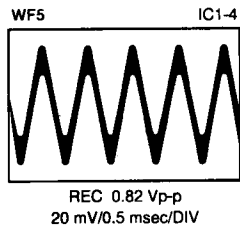
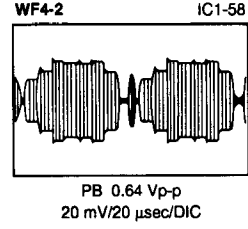
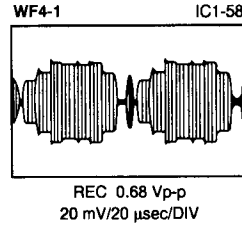
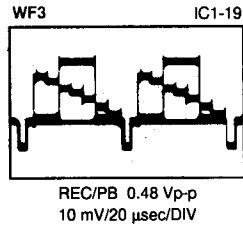
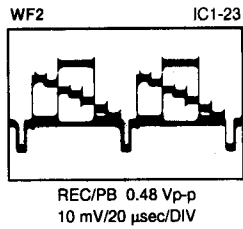
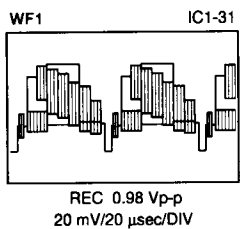
SYMBOL	Q7102	Q7103	R7101	R7102	R7105	R7106	R7118	R7119	R7120	C7101	C7102	C7103	C7107	C7110	L7101
MODEL	VR488/55	VR588/55	VR488/55	VR588/55	VR488/55	VR588/55	VR488/55	VR588/55	VR488/55	VR588/55	VR488/55	VR588/55	VR488/55	VR588/55	VR488/55
	NOT USED	USED	NOT USED	USED	NOT USED	USED	NOT USED	USED	NOT USED	NOT USED	NOT USED	NOT USED	NOT USED	NOT USED	NOT USED



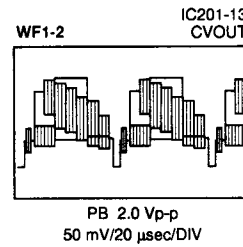
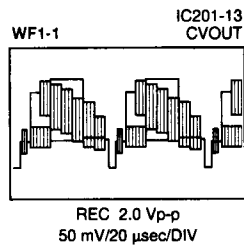
L7102	L7103	L7104	J7101	D7151	D7152	R7151	R7152	R7153	R7154	C7151	C7152	C7156	L7151	L7152	L7153	J7151	J7152
NOT USED	NOT USED	NOT USED	NOT USED	USED	USED	USED	USED	USED	USED	USED	USED	USED	USED	USED	USED	USED	USED
USED	USED	USED	USED	NOT USED	NOT USED	NOT USED	NOT USED	NOT USED	NOT USED	NOT USED	NOT USED	NOT USED	NOT USED	NOT USED	NOT USED	NOT USED	NOT USED

WAVEFORMS

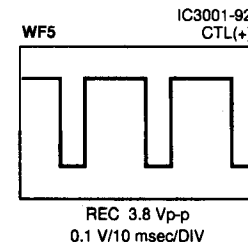
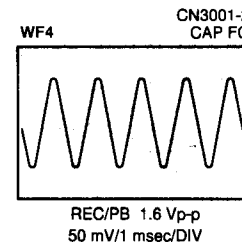
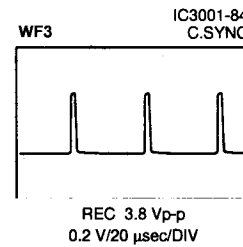
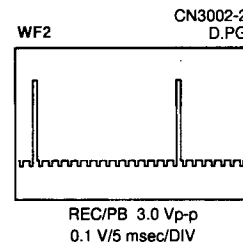
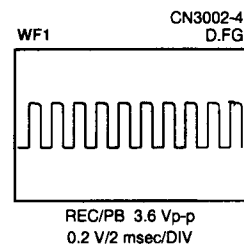
— VIDEO/N.AUDIO —



— ON SCREEN —

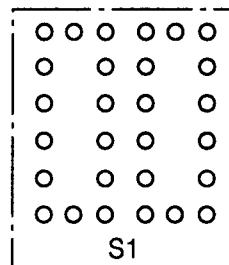
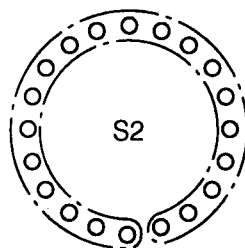
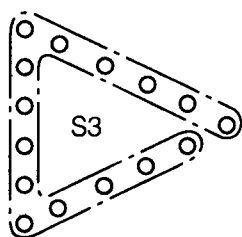
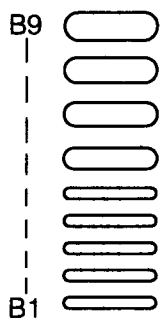
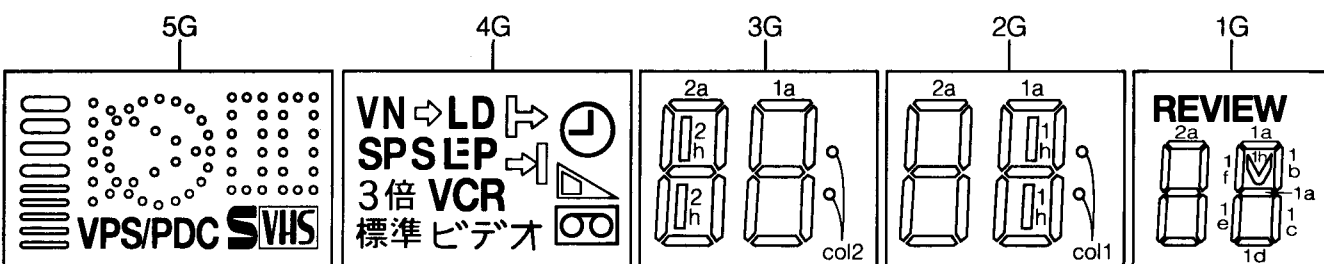


— SYSCON —



FDP GRID ASSIGNMENT AND ANODE CONNECTION

GRID ASSIGNMENT



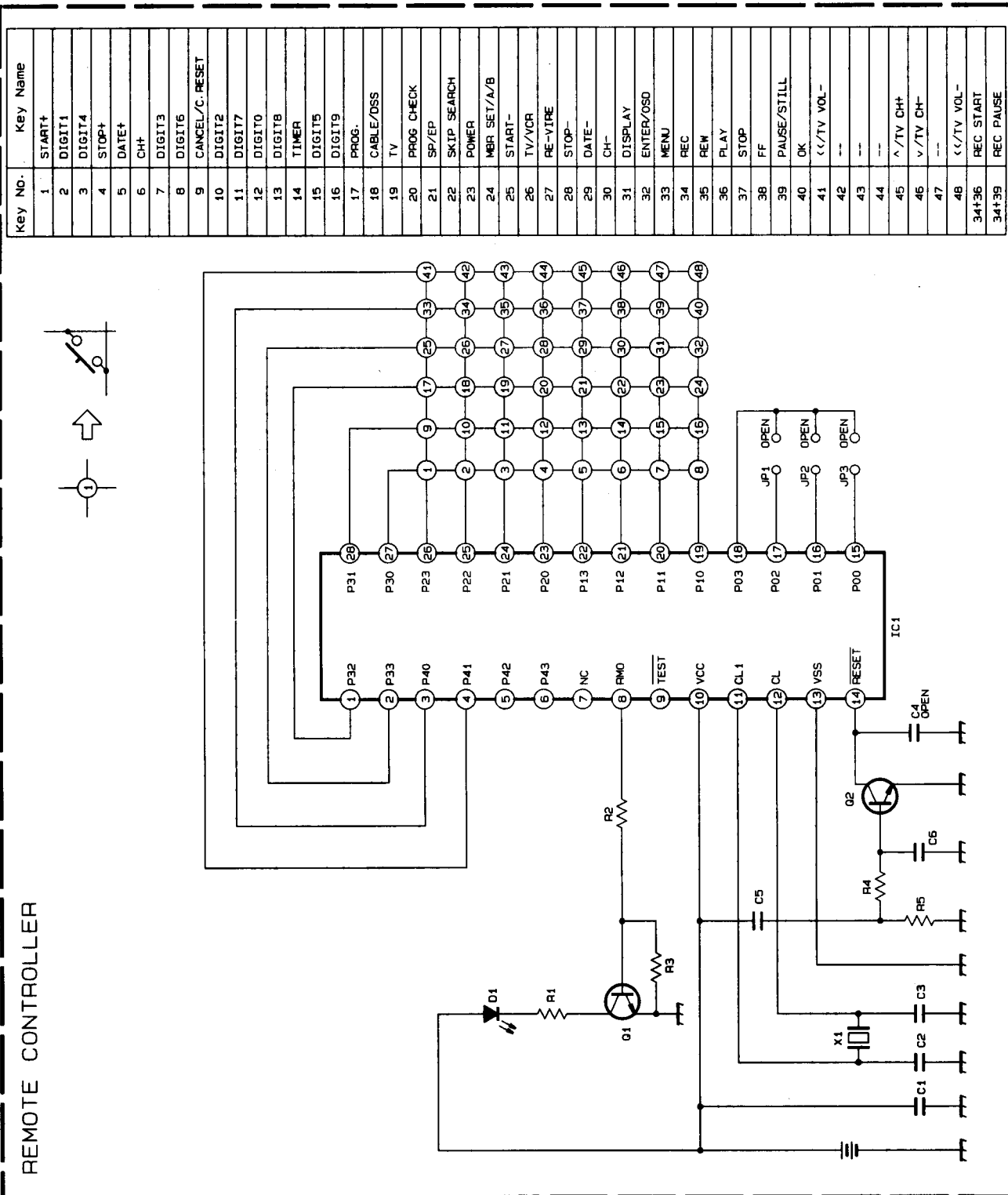
(5G)

ANODE CONNECTION

	5G	4G	3G	2G	1G
P 1	S2	↗	1a	1a	1a
P 2	S1	↘	1b	1b	1b
P 3	S3	3倍	1f	1f	1f
P 4	VPS/PDC	標準	1g	1g	1g
P 5	SVHS	⌚	1c	1c	1c
P 6	—	▴	1e	1e	1e
P 7	—	⊞	1d	1d	1d
P 8	B9	VCR	col2	1h	1h
P 9	B8	ビデオ	2a	2a	2a
P10	B7	⇨	2b	2b	2b
P11	B6	VN	2f	2f	2f
P12	B5	LD	2g	2g	2g
P13	B4	SP	2c	2c	2c
P14	B3	S _(SEP)	2e	2e	2e
P15	B2	⋮ _(SEP)	2d	2d	2d
P16	B1	LP _(SEP)	2h	col1	REVIEW

4.12 REMOTE CONTROL SCHEMATIC DIAGRAM

NOTES:
 1. All parts shown in this schematic are critical for safety.
 2. This schematic is only for reference.
 Avoid replacing individual parts.
 Replace the entire unit only.

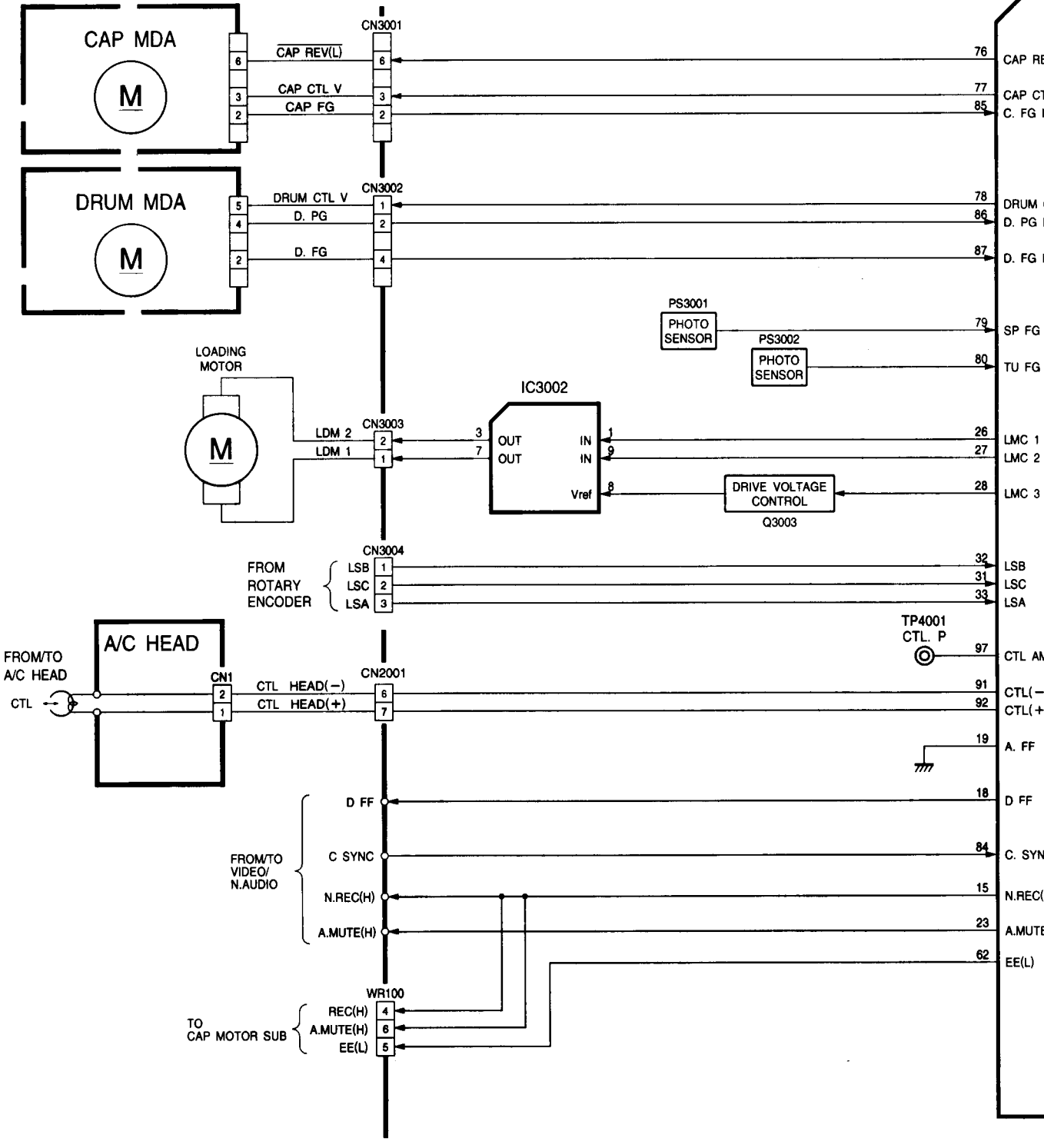


REMOTE CONTROLLER

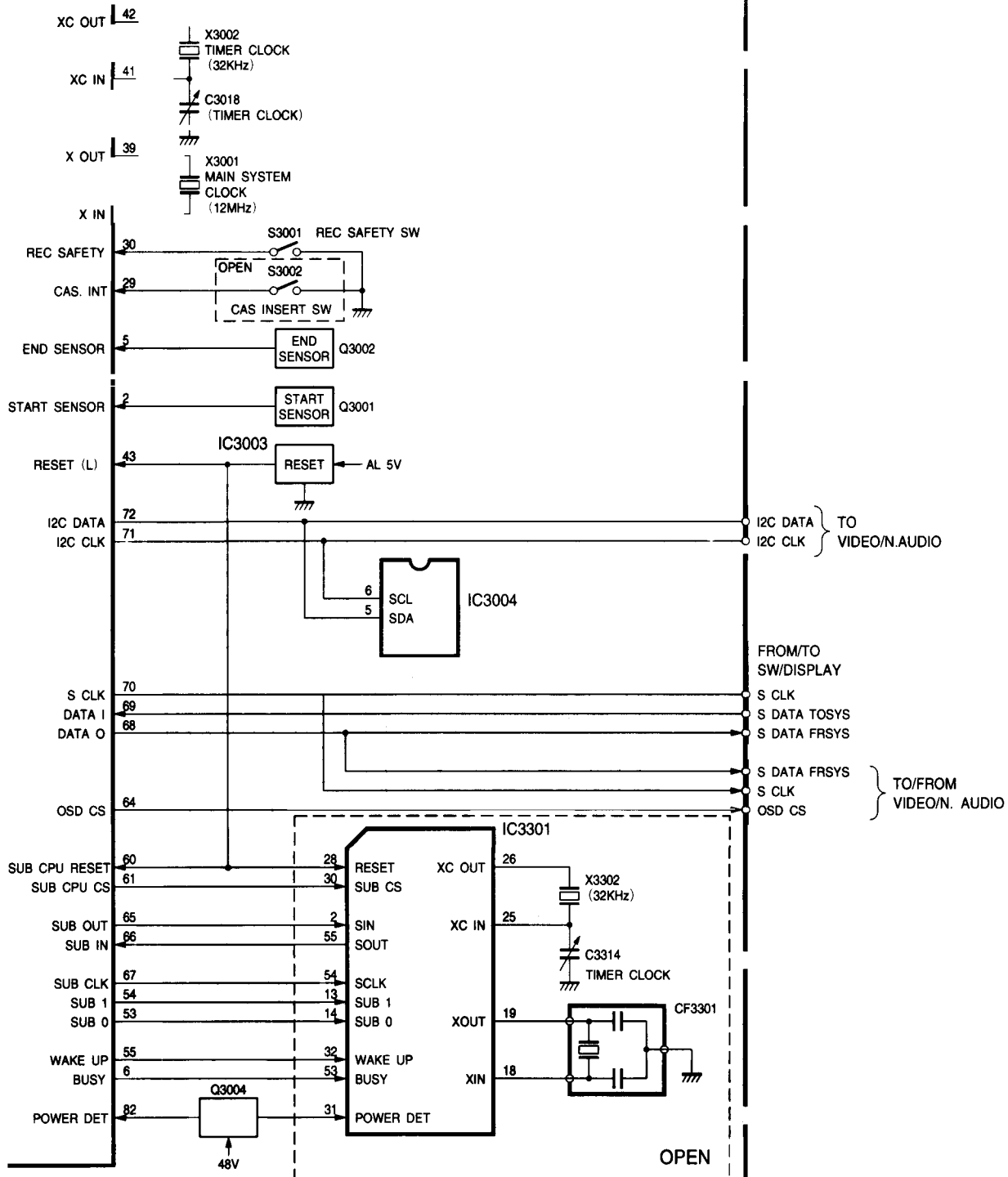
4.14 SYSTEM CONTROL BLOCK DIAGRAM

03 MAIN (SYSCON)

5
4
3
2
1



IC3001



0 3 MAIN (VIDEO/ON SCREEN/Terminal)

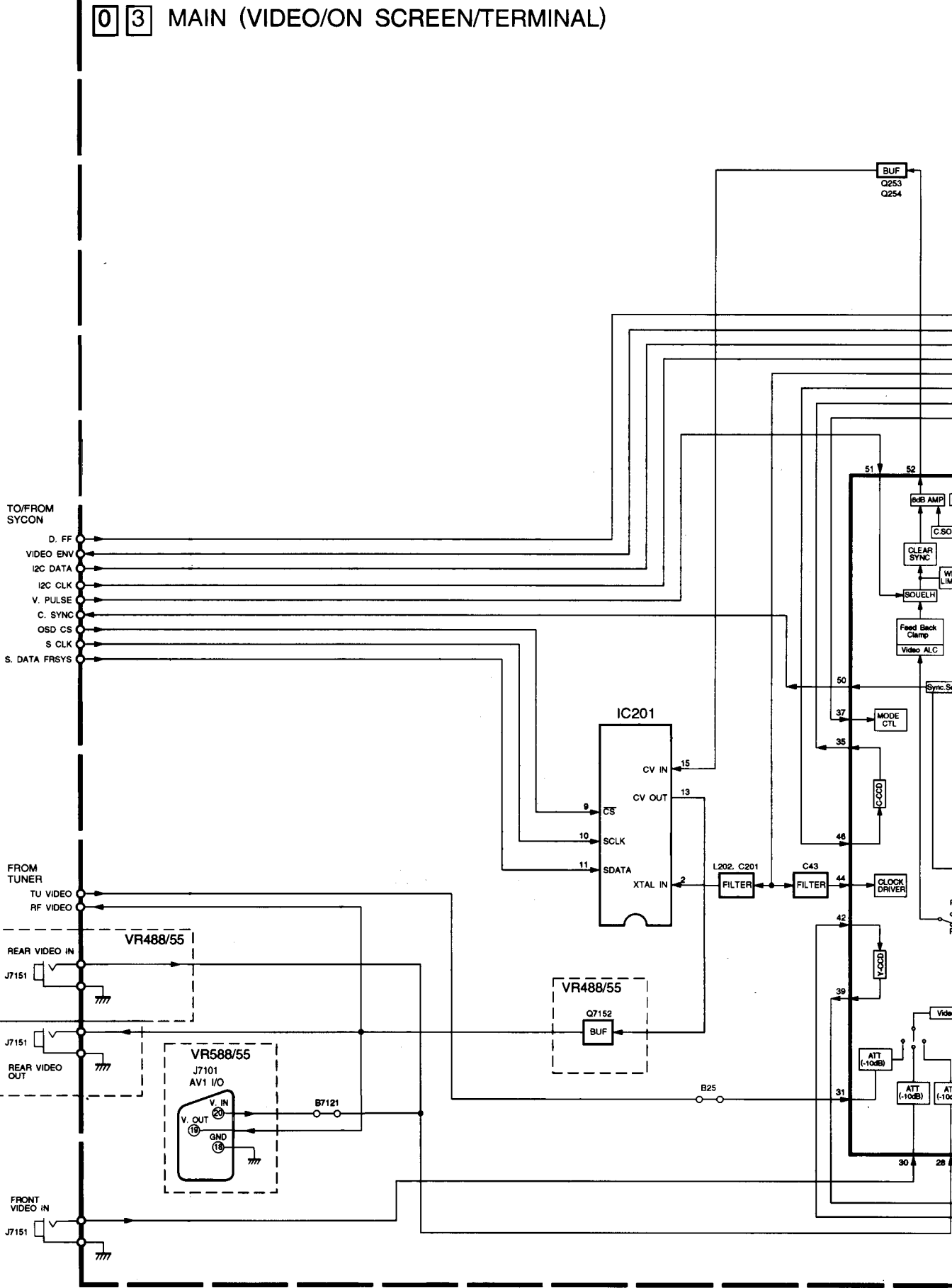
5

4

3

2

1

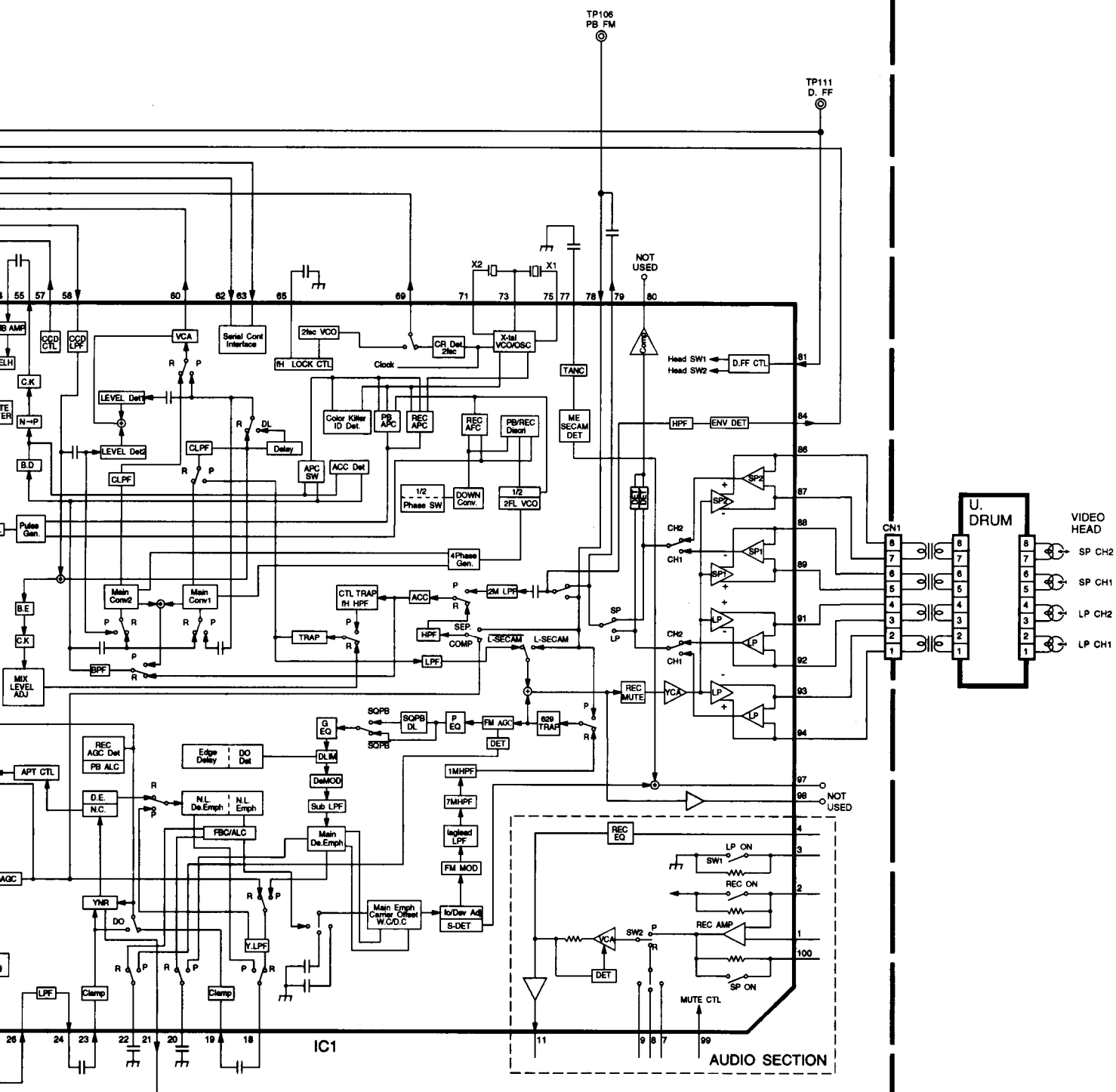


A

B

C

D



4.16 AUDIO BLOCK DIAGRAM

5

0 3 MAIN (N. AUDIO/TERMINAL)

TO/FROM
TUNER

RF AUDIO
TU AUDIO

B7123

VR488/55

REAR AUDIO IN

J7151

REAR AUDIO OUT

J7152

4

3

J7101
AV1 I/O

VR588/55

A. OUT(R)

L7103, C7110

1

2

A. IN(R)

A. OUT(L)

3

GND

4

A. IN(L)

6

L7101, L7102
C7101, C7102
R7105, R7106

4

B7122

2

FRONT AUDIO IN

J7104

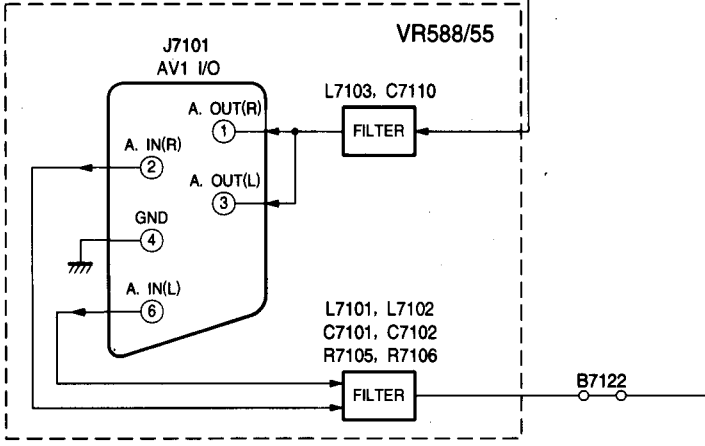
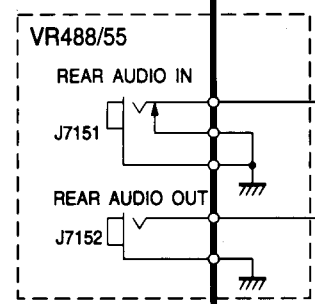
1

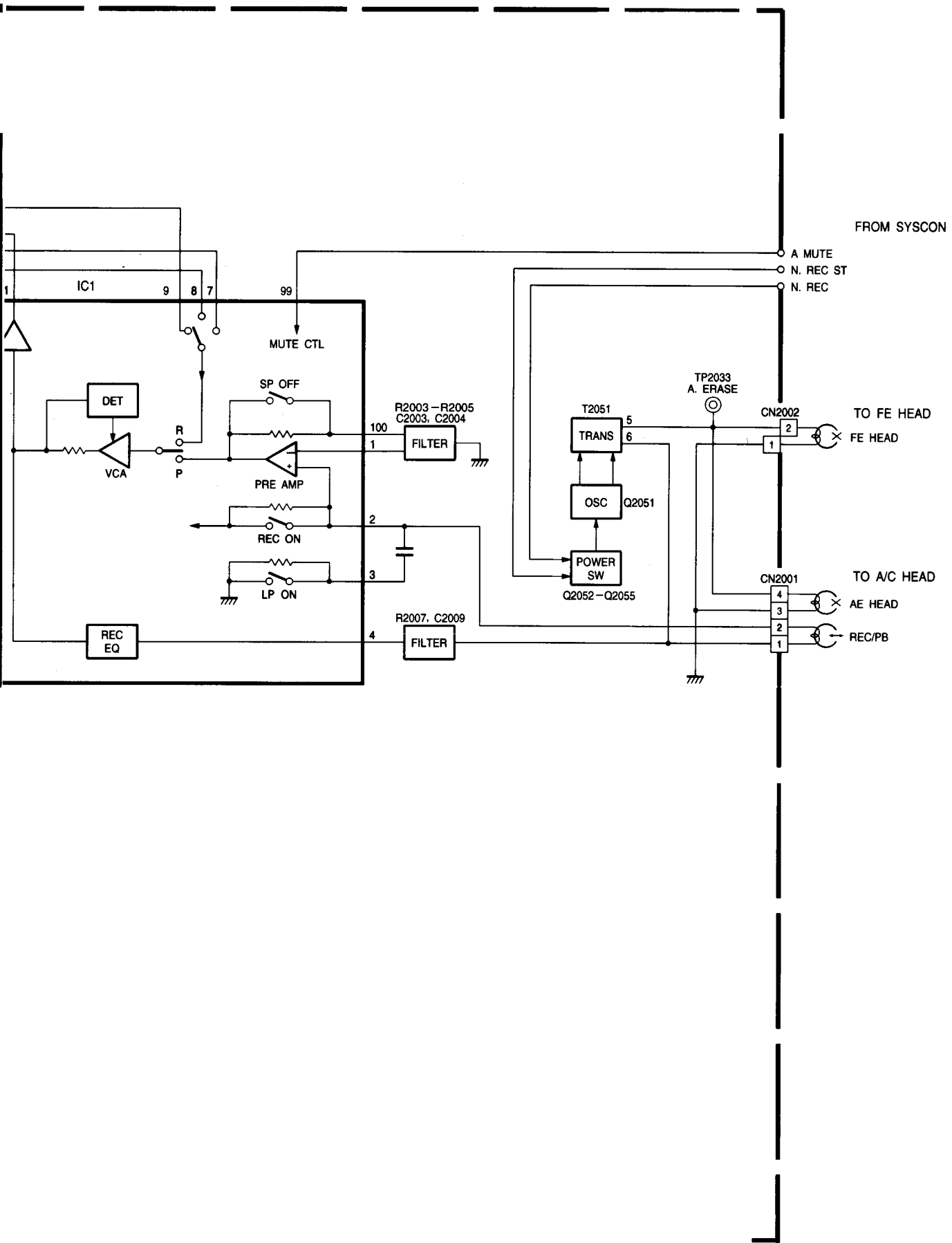
A

B

C

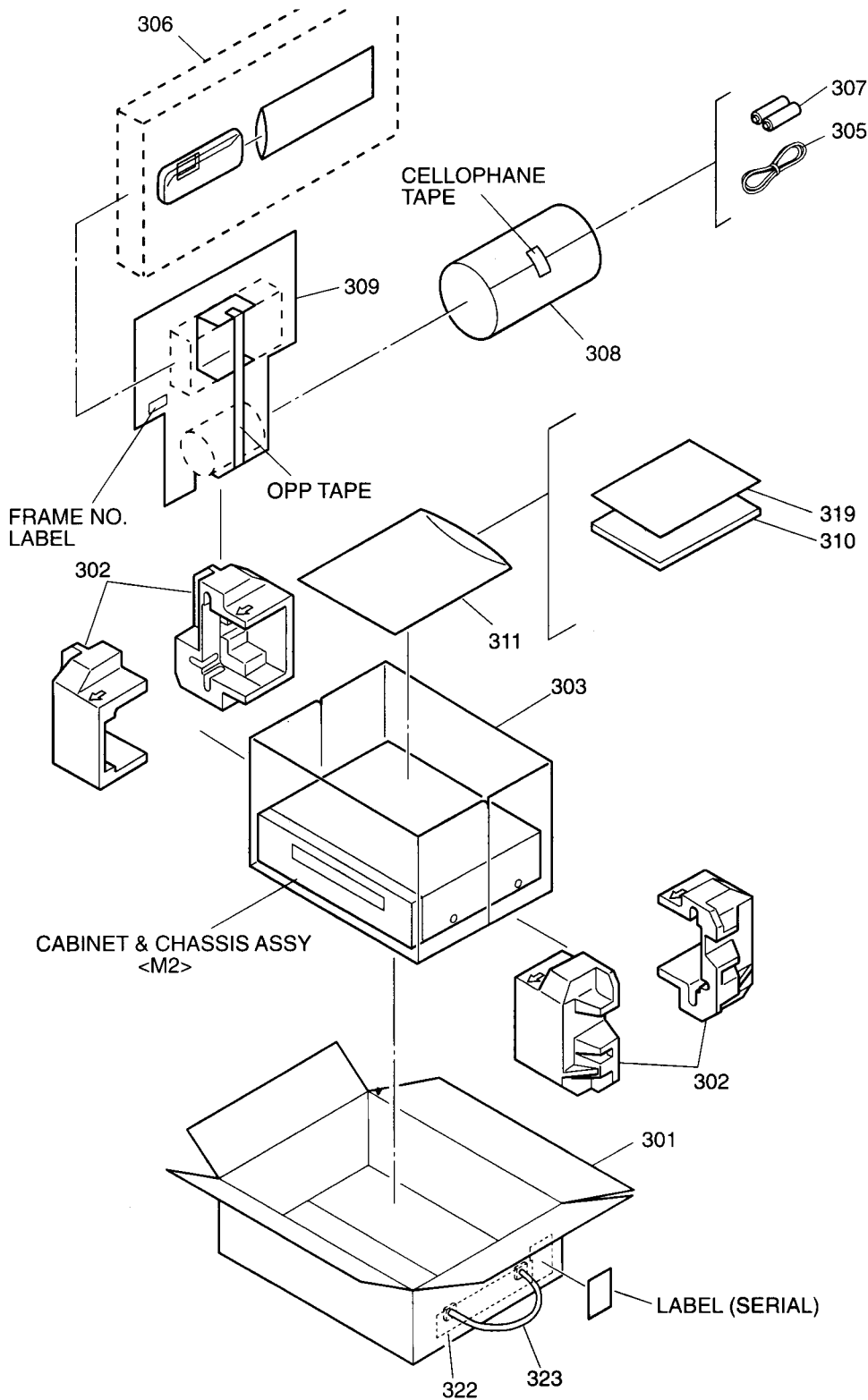
D



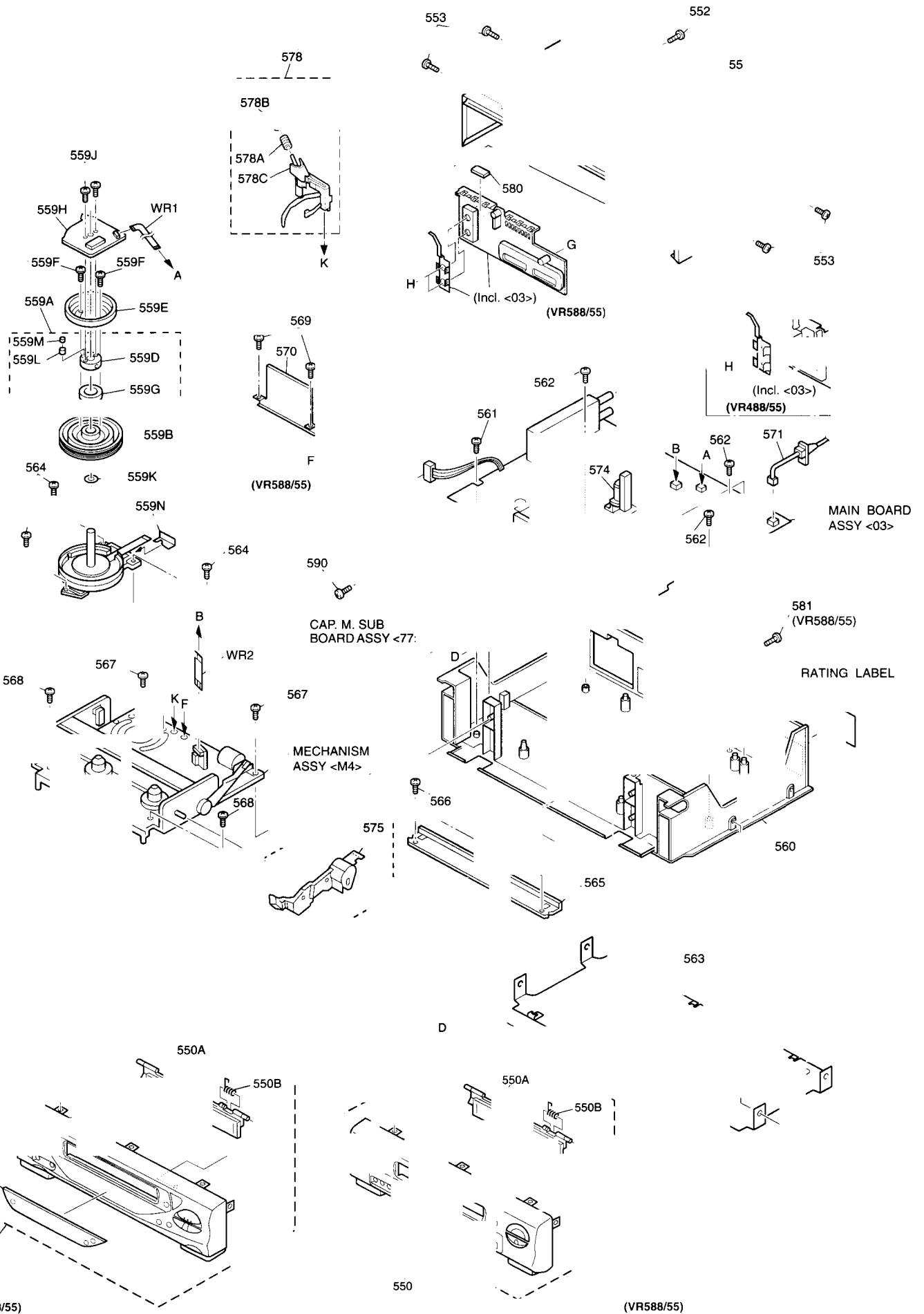


CTION PARTS LIST

PACKING AND ACCESSORY ASSEMBLY



5.2 CABINET AND CHASSIS ASSEMBLY



2. PACKING AND ACCESSORY ASSEMBLY <M1>

306	4822 219 10524	REMOTE CONTROLLER
310	! 4822 736 16215	INST BOOK(EN,CH),VR488/55
	! 4822 736 16216	INST BOOK(RU,AR),VR488/55
	! 4822 736 16218	INST BOOK,VR588/55

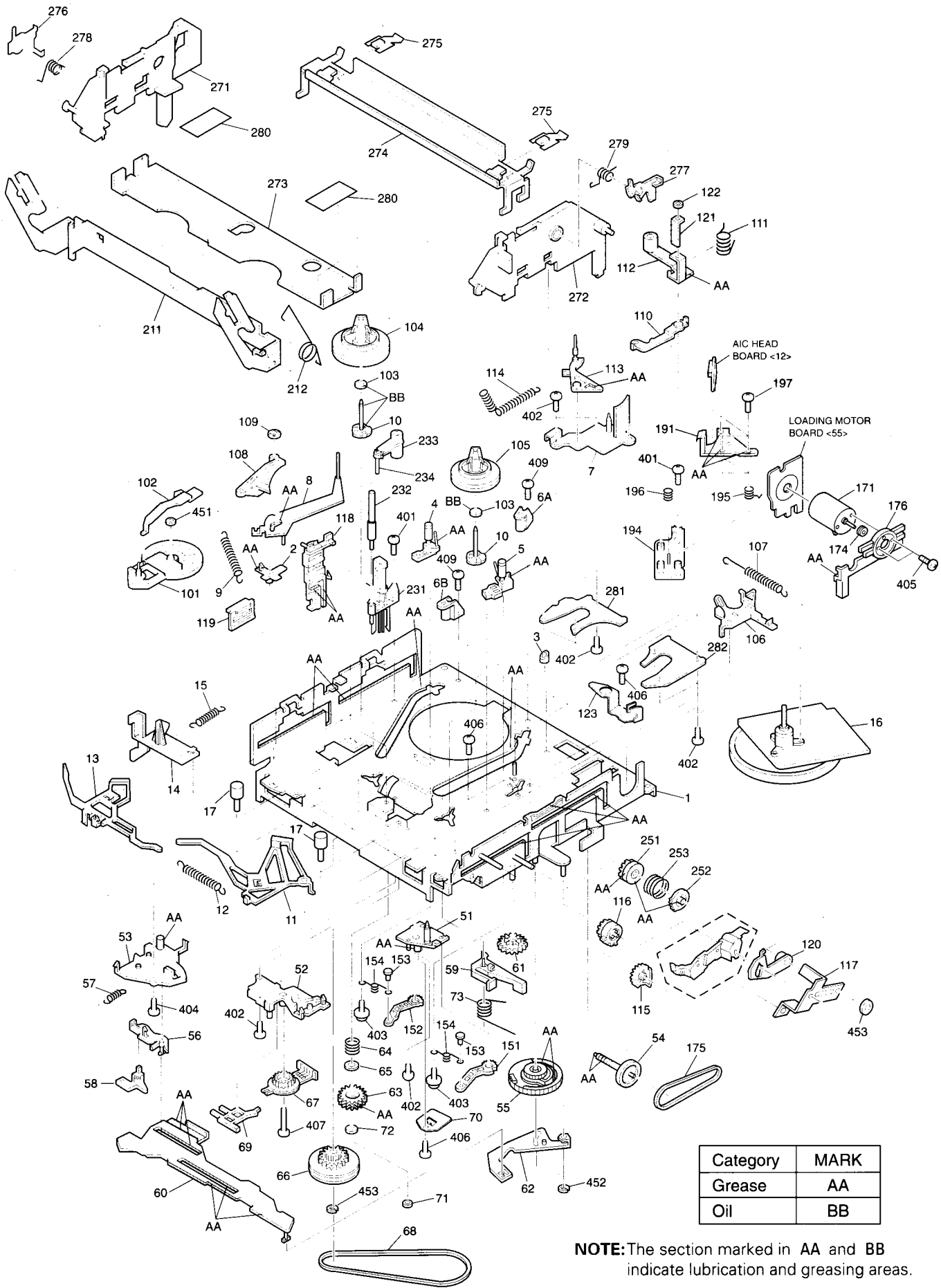
3. CABINET AND CHASSIS ASSEMBLY <M2>

550	! 4822 459 05015	FRONT PANEL ASSY,VR488/55
550	! 4822 459 05016	FRONT PANEL ASSY,VR588/55
550A	4822 443 10915	CASSETTE DOOR,VR488/55
	4822 443 11026	CASSETTE DOOR,VR588/55
550B	4822 492 42781	TORSION SPRING
559A	4822 691 10721	DRUM SUB ASSY
559B	4822 691 10622	UPPER DRUM ASSY
559D	4822 532 12803	COLLAR ASSY
559E	4822 362 10295	ROTOR ASSY
559G	4822 462 10924	CAP
559H	4822 362 10296	STATOR ASSY
559K	4822 532 12804	WASHER
559L	4822 265 11367	CONTACT
559M	4822 492 11666	COMPRESS.SPRING
559N	4822 466 12015	FPC PLATE
574	4822 462 11111	STOPPER
575	4822 402 11102	DOOR OPENER
578	4822 528 11247	CLEANER ASSY
580	4822 532 13036	SPACER,VR588/55

WIRE

WR1	4822 320 12426	FFC WIRE,DRUM
WR2	4822 320 12418	E-CARD WIRE,A/C HEAD

5.3 MECHANISM ASSEMBLY



Category	MARK
Grease	AA
Oil	BB

NOTE: The section marked in AA and BB indicate lubrication and greasing areas.

4. MECHANISM ASSEMBLY <M4>

2	4822 532 13037	T.ARM BEARING	110	4822 402 11057	P.LEVER ASSY
3	4822 462 11105	G.POLE CAP	111	4822 492 11634	TORSION SPRING
4	4822 402 11035	POLE BASE ASSY(S)	112	4822 402 11133	P.R.ARM ASSY
5	4822 402 11036	POLE BASE ASSY(T)	113	4822 402 11059	GUIDE ARM ASSY
6A	4822 402 11132	UV CATCHER(S)	114	4822 492 11635	TENSION SPRING
6B	4822 402 11042	UV CATCHER2(T)	115	4822 522 10702	DRIVE GEAR
7	4822 463 11196	LID GUIDE	116	4822 522 10703	RELAY GEAR
8	4822 402 11043	TENSION ARM ASSY	117	4822 402 11128	C.H.BRACKET
9	4822 492 11629	TENSION SPRING	118	4822 463 11206	GUIDE RAIL
10	4822 535 10565	REEL SHAFT,X2	119	4822 462 11106	RAIL CAP
11	4822 402 11044	MAIN BRAKE ASSY(TAKE-UP)	120	4822 402 11061	OPENER GUIDE
12	4822 492 11667	TENSION SPRING	121	4822 402 11134	P.R.SHEET,P.R.ARM
13	4822 402 11045	MAIN BRAKE ASSY (SUPPLY)	122	4822 532 13042	SLIT WASHER,P.R.ARM
14	4822 402 11127	REC SAFTY LEVER	123	4822 463 11207	P.ROLLER GUIDE
15	4822 492 11668	TENSION SPRING	151	4822 402 11062	LOADING ARM GEAR(T)
16	4822 361 11094	CAPSTAN MOTOR	152	4822 402 11063	LOADING ARM GEAR(S)
17	4822 535 10317	ADJUST PIN,X2	153	4822 535 10566	PIN,LOADING ARM(S)
51	4822 535 10568	LOADING ARM GEAR SHAFT		4822 535 10566	PIN,LOADING ARM(T)
52	4822 463 11197	R.ENCODER GUIDE	154	4822 492 11636	TORSION ARM,L.ARM GEAR(S)
53	4822 466 11931	CTL.PLATE GUIDE		4822 492 11636	TORSION ARM,L.ARM GEAR(T)
54	4822 522 10697	WORM GEAR	171	4822 361 11095	LOADING MOTOR
55	4822 528 11256	CTL.CAM	174	4822 528 81557	MOTOR PULLEY
56	4822 402 11046	T.UP LEVER	175	4822 358 10256	BELT
57	4822 492 11631	TENSION SPRING	176	4822 463 11198	MOTOR GUIDE
58	4822 402 11047	T.UP HEAD	191	4822 249 10557	AC HEAD
59	4822 402 11048	C.BRAKE ASSY	194	4822 464 10456	HEAD BASE
60	4822 466 11932	CTL.PLATE	195	4822 492 11671	COMPRESSION SPRING,X3
61	4822 522 10698	CASSETTE GEAR	196	4822 492 11672	COMPRESSION SPRING
62	4822 402 11049	LINK LEVER ASSY	211	4822 402 11064	DRIVE ARM
63	4822 522 10699	DIRECT GEAR	212	4822 492 11673	TORSION SPRING
64	4822 492 11669	COMPRESSION SPRING	231	4822 249 10558	FULL ERASE HEAD
65	4822 532 13038	SPACER,D.GERA	232	4822 463 11208	GUIDE POLE(S)
66	4822 522 10701	CLUTCH UNIT	233	4822 464 10457	TENSION STUD BASE
67	4822 273 10349	ROTARY ENCODER	234	4822 535 10567	TENSION STUD
68	4822 358 10255	BELT	251	4822 522 10704	LIMIT GEAR(1)
69	4822 402 11051	CHANGE LEVER	252	4822 522 10705	LIMIT GEAR(2)
70	4822 402 11052	CTL.BRACKET(1)	253	4822 492 11674	TORSION SPRING
71	4822 532 13041	SLIT WASHER	271	4822 256 10498	SIDE HOLDER(L)
72	4822 532 13039	SPACER,D.GEAR	272	4822 256 10499	S.HOLDER(R)ASSY
73	4822 492 11632	TORSION SPRING,C.BRAKE	273	4822 256 10469	CASSETTE HOLDER
101	4822 402 11053	IDLER ARM ASSY	274	4822 466 12027	TOP PLATE
102	4822 402 11054	IDLER LEVER	275	4822 492 11675	SPRING PLATE,X2
103	4822 532 13043	SPACER,X2,REEL DISK	276	4822 402 11129	LOCK LEVER(L)
104	4822 528 11257	REEL DISK (SUPPLY)	277	4822 402 11131	LOCK LEVER(R)
105	4822 528 11258	REEL DISK (TAKE-UP)	278	4822 492 11664	TOR.SPRING(L)
106	4822 402 11055	S.BRAKE(T)ASSY	279	4822 492 11665	TOR.SPRING(R)
107	4822 492 11633	TENSION SPRING	451	4822 532 13041	SLIT WASHER, IDLER ARM
108	4822 402 11056	T.BRAKE ASSY	452	4822 532 11784	SLIT WASHER, CONTROL CAM
109	4822 535 10317	ADJUST PIN		4822 532 11784	SLIT WASHER, LINK LEVER
			453	4822 532 12326	SLIT WASHER, CLUTCH
				4822 532 12326	SLIT WASHER, C.H.BRACKET